



The bridge to possible

Cisco SD-Access Best Practices – Design & Deployment

Mahesh Nagireddy , Technical Marketing Engineering, Technical Leader
CCIE R&S

Cisco Webex App

Questions?

Use Cisco Webex App to chat with the speaker after the session

How

- 1 Find this session in the Cisco Live Mobile App
- 2 Click “Join the Discussion”
- 3 Install the Webex App or go directly to the Webex space
- 4 Enter messages/questions in the Webex space

Webex spaces will be moderated until February 24, 2023.

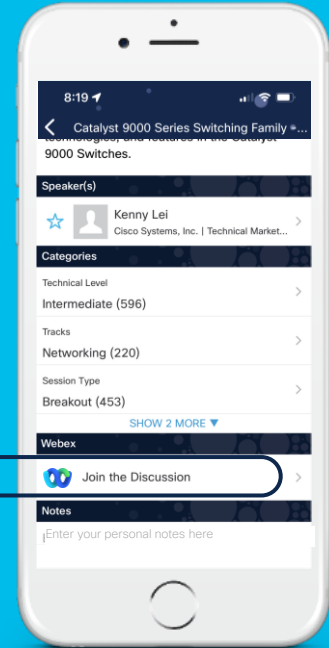



Agenda

- Introduction
- SD-Access Scale & Readiness
- SD-Access Single-Site Design Options
- SD-Access Multi-Site Design Options
- SD-Access Policy Design Options

SD-Access Platform Support

Digital Platforms for your Cisco Digital Network Architecture



For more details: cs.co/sda-compatibility-matrix

Cisco Software-Defined Access Compatibility Matrix

Select Deployment

New Deployment Upgrade

New Deployment

Release:

Device Role:

- ISE
- Fabric Edge
- Fabric Border and Control Plane
- Wireless
- Extended Node or IOT Extension for SD-Access
- SD-WAN Integrated Domain Solution
- Collocated SD-Access Border, Control Plane and SD-WAN WAN Edge
- SD-WAN Controller

[Site Map](#) [Terms & Conditions](#)

Platform support based on the Fabric Role

Cisco Software-Defined Access Compatibility Matrix

Select Deployment

New Deployment Upgrade

New Deployment

Release:

Device Role:

SD-Access Compatibility Matrix for Cisco DNA Center 2.2.3.5 (recommended release)

Device Role	Device Series	Device Model	Recommended Release	Supported Release
Fabric Border and Control Plane	Cisco ASR 1000-X and 1000-HX Series Aggregation Services Routers	ASR 1001-HX ASR 1001-X ASR 1002-HX ASR 1002-X ASR 1006-X (RP2) More ...	IOS XE 17.6.2	IOS XE 17.6.x IOS XE 17.5.x IOS XE 17.3.x IOS XE 16.9.1s IOS XE 16.9.2 More ...

Supported Hardware, Software and Recommended Version for all Cisco SD-Access components

Cisco SD-Access Scale & Readiness

[Cisco DNA Center 2.3.3\(Guardian\) Data Sheet](#)

Cisco DNA Center Fabric Readiness and Compliance Checks

- Connectivity checks
- Existing configuration check
- Loopback check
- Hardware Version
- Image Type
- Software Version
- Software Licenses

Software Licensing

- Cisco DNA Advantage/Cisco DNA Premier License

Cisco SD-Access

Latency Requirements

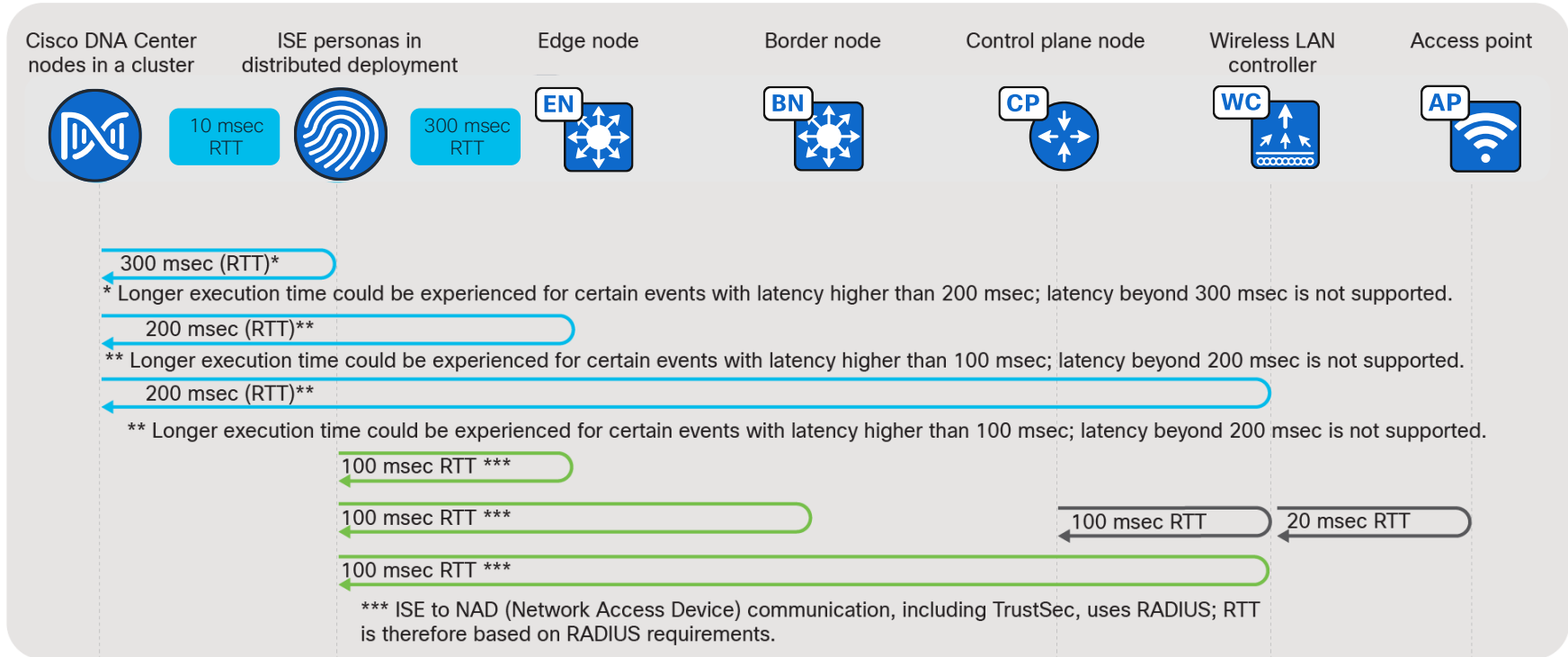

Cisco SD-Access

Cisco DNA Center Deployment

• Deployment Types

- Standalone
- Cluster for High Availability (HA)
 - Cluster interconnected with 10Gbps interface with <10msec latency
- Disaster Recovery (DR) for network downtime
 - Cluster connected with 1Gbps interface between main site and recovery site with <350 msec latency

• Failure detection and recovery

	High Availability	Disaster Recovery
Failure Detection time	5 minutes	3 minutes
Time taken to failover on failure detection	7-13 minutes	15-30 minutes
Failover time behavior	Service down upto 7 minutes	Service down upto 30 minutes
Failback	Automatic	Manual



Disaster Recovery

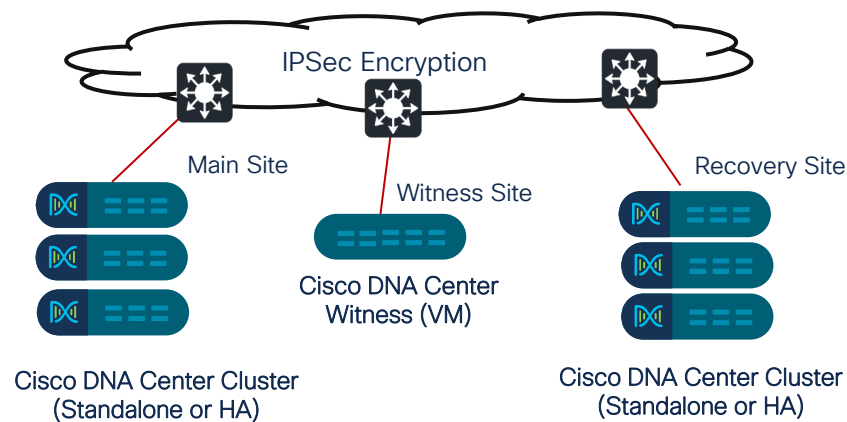

Cisco SD-Access Architecture

Where do I place Critical/Shared Services

Local DC or Services Block

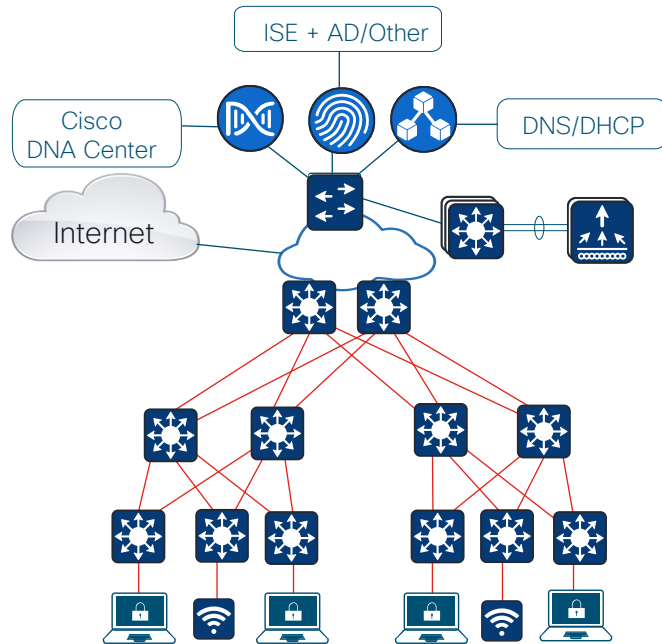

Remote DC

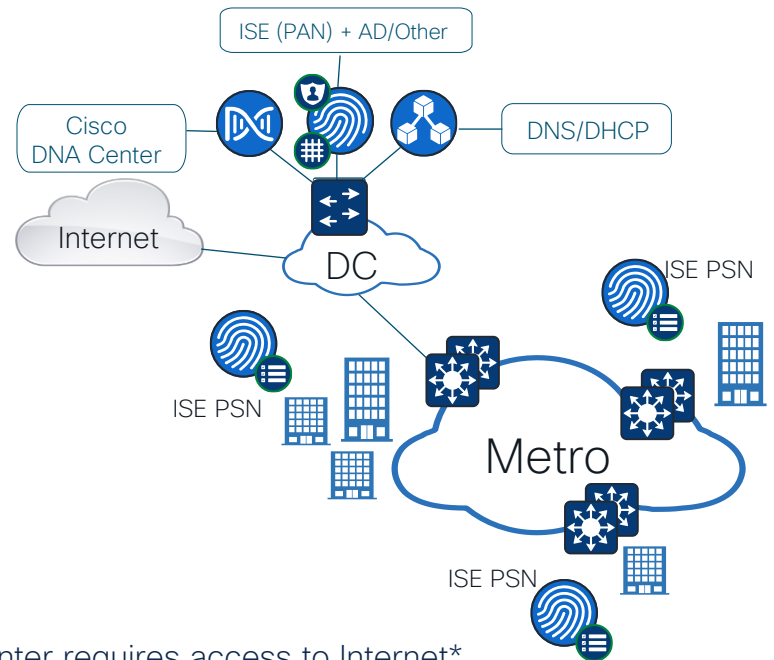

Cisco DNA Center requires access to Internet*

Cisco SD-Access Policy Segmentation Strategy

Macro Segmentation

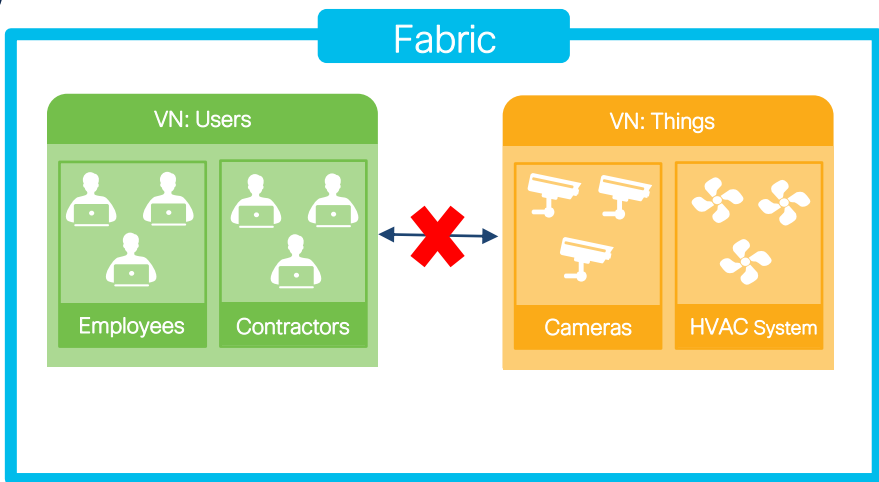

Virtual Network (VN)

- VN = VRF = LISP Instance ID
- Complete Isolation between VN's
- Default Policy: No communication

Micro Segmentation

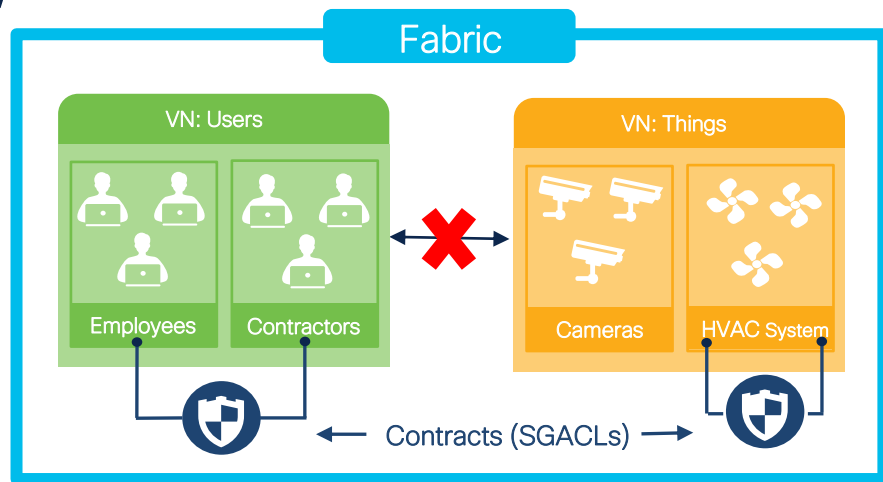

Security Group Tag (SGT)

- Location Independent Policy
- Simple Permit/Deny/Contracts
- Default Policy: Permit/Deny

SD-Access Flexible Deployment Options

I am installing a new network and want zero trust



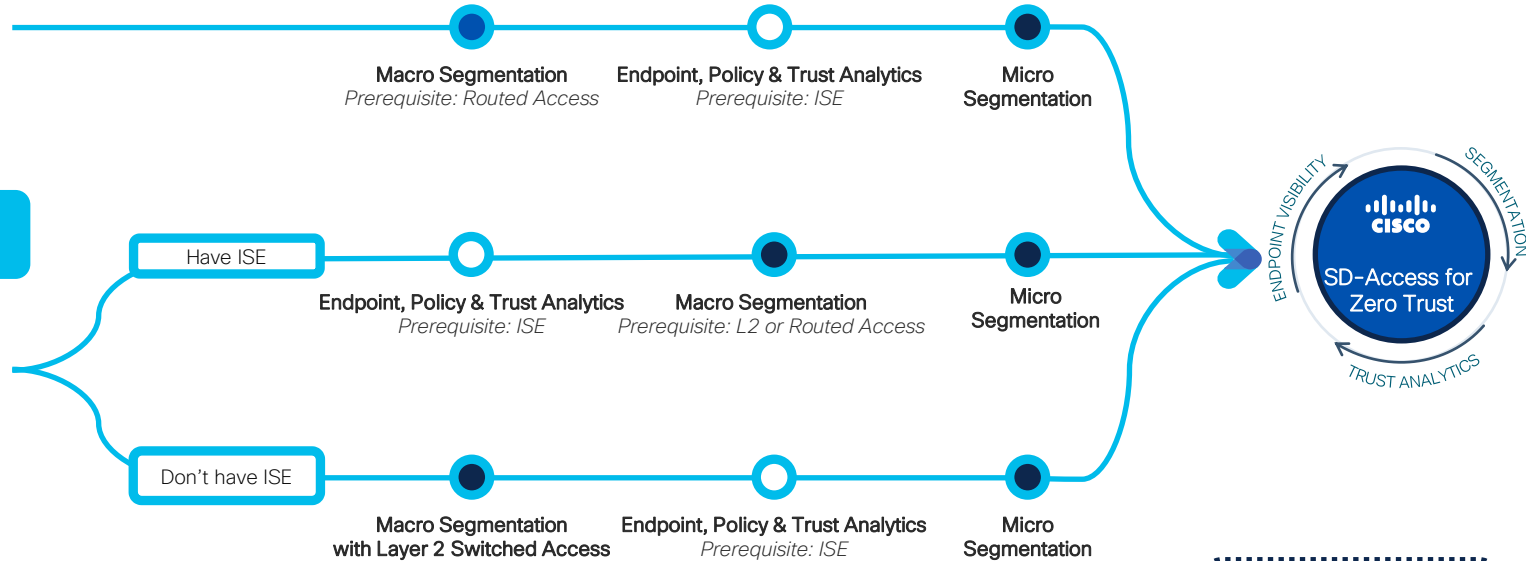

I have an existing network and want zero trust



SD-Access Flexible Deployment Options

Migration Options

 Macro segmentation
 Micro segmentation

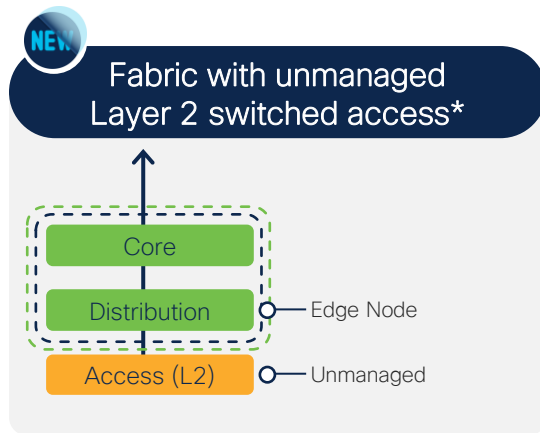

Use case: Keep your existing unmanaged switches

- Segmentation starts at distribution layer
- Integrated wired and wireless

Benefit: Allow tenants to bring their own network.

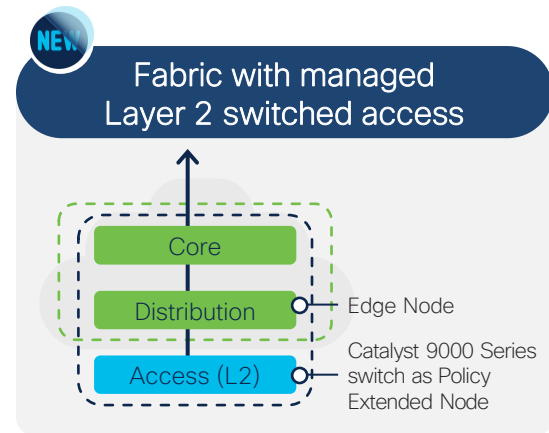

Use case: Retain Layer 2 access

- Extend segmentation down to Layer 2
- Integrated wired and wireless

Benefit: Security and automation at every layer

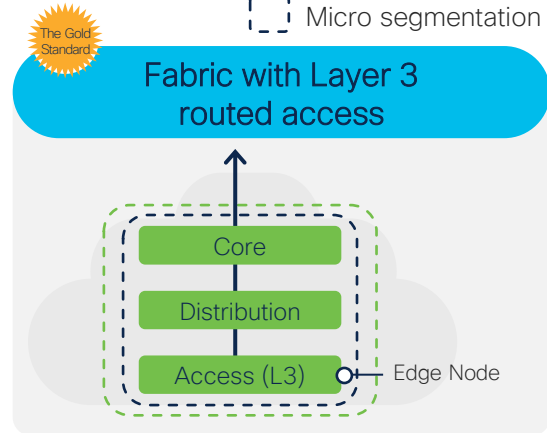

Use case: Full SD-Access

- Full stack macro and micro segmentation
- Integrated wired and wireless
- Policy-based traffic steering
- Topology independence

Benefit: Experience all that SD-Access offers

*Available with Cisco DNA Center release 2.2.1.0, generally available in late Q2 CY 2021

Cisco SD-Access Scale & Readiness

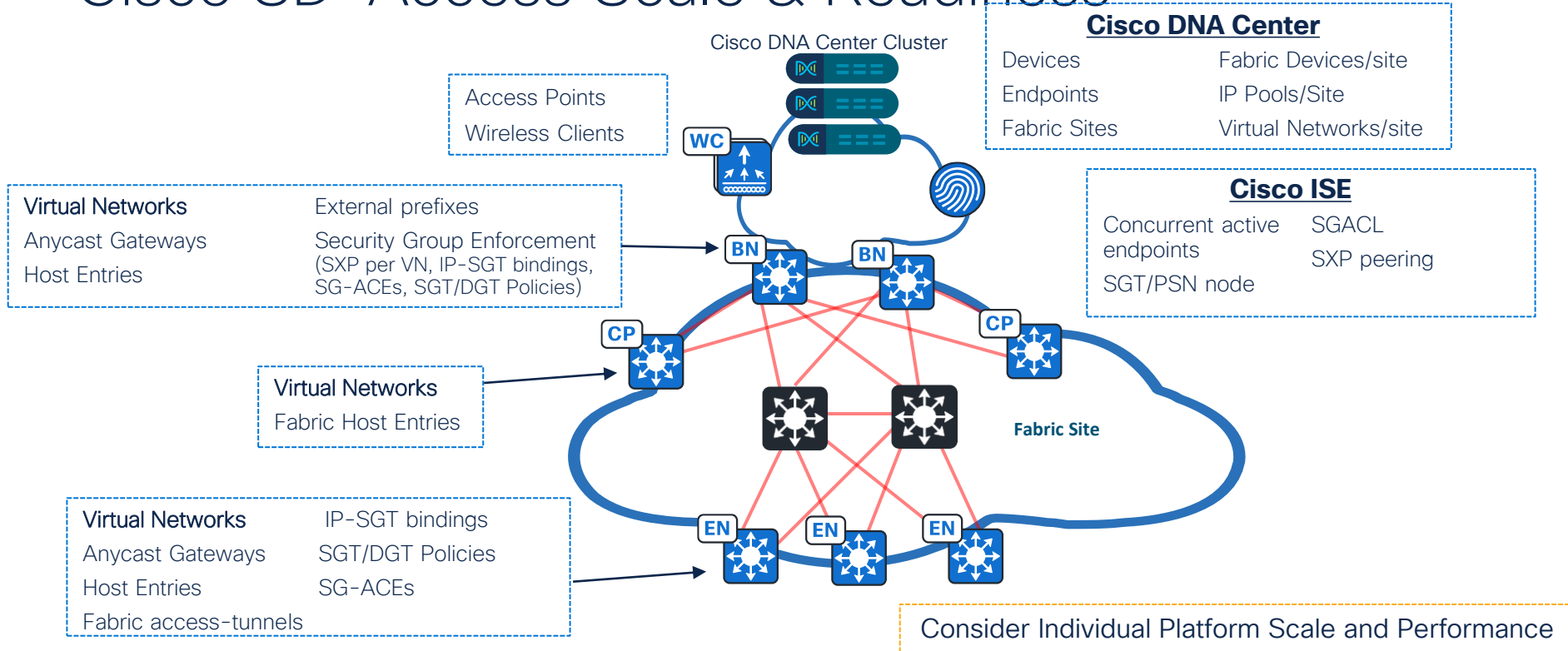

Least Common Denominator (LCD) across the solution elements

Cisco SD-Access Single-site Design Options

Fabric Site Design Options

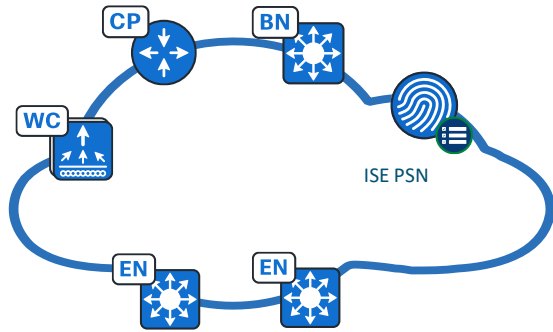

Fabric Site

- Logical construct that contains:
 - Fabric Edge, Border, Control Plane
 - ISE PAN/PSN Node
 - (optional) Wireless LAN Controller, Access Points
 - (optional) Extended Nodes

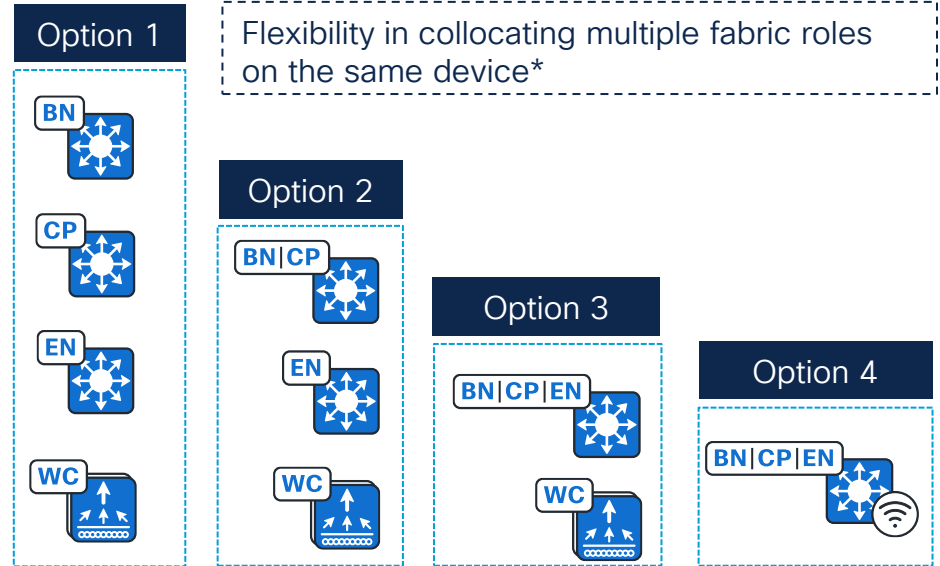

* Refer to Cisco SD-Access compatibility matrix for latest information

Fabric Network Infrastructure

Robust Underlay Infrastructure deployment

- Routed Access Network
- Any routing protocol
- Resilient and Redundant fast-converged connectivity with ECMP, BFD enabled.
- Loopback 0 with /32 host prefix.
- Higher MTU to accommodate VXLAN encapsulation
- Underlay multicast to optimize overlay subnet multicast/broadcast distribution

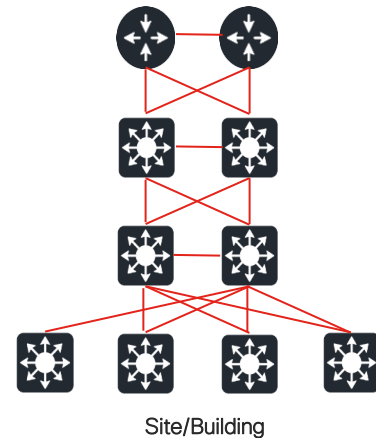

Manual | Semi-Automated Underlay

Device-by-Device onboarding and configuration either manually or through Cisco DNA Center Plug-and-Play.

Automated Underlay(Lan Automation)

Turnkey solution to onboard multiple switches with image management and best-practices configuration.

Cisco SD-Access Provision

Fabric Control Plane enhancements

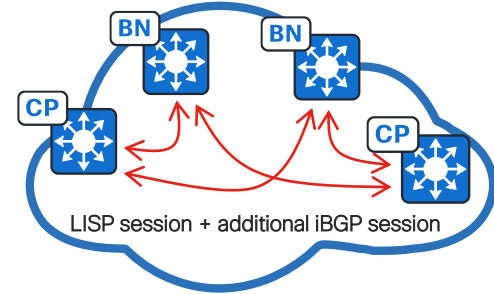
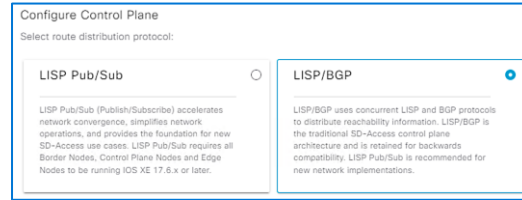
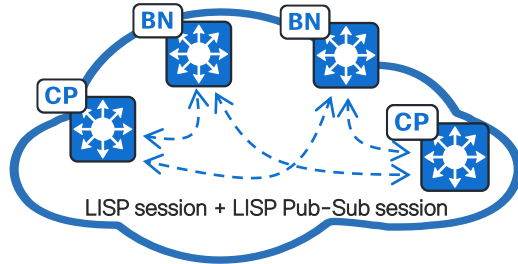

LISP Pub/Sub

- Publisher-Subscriber model provides LISP Instance-ID table subscription from CP, TCP to Border nodes.
- Faster convergence within fabric site (N-S traffic) and across SD-Access transit.
- LISP Pub/Sub provides backbone for fabric innovations such as **Dynamic-Default Border**, **Extranet**, **Active-Backup Internet (with SD-Transit)** and more..
- 4 TCP(Transit Control Plane) Node support

LISP / BGP

- iBGP session between B - CP and B - TCP node to share prefixes.
- Convergence overhead with additional protocol, redistribution and additional lookups
- Troubleshooting complexity with 2 Control-plane protocols
- Only 2 TCP Node support

Cisco SD-Access Provision

Fabric Control Plane enhancements Cont'd

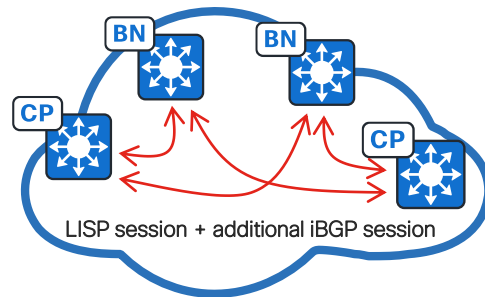
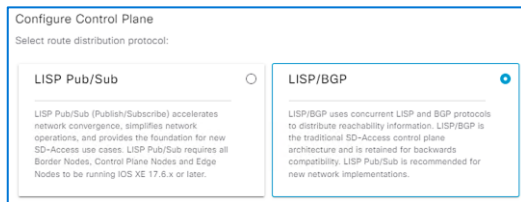
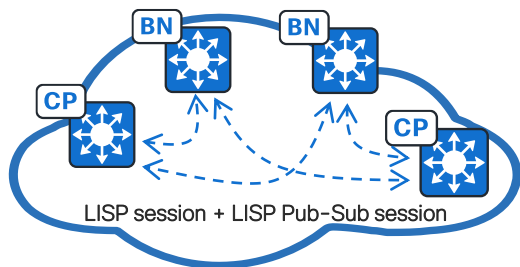

LISP Pub/Sub Benefits

- Remove dependency on BGP
- Simplified Border Routing Designs
- Faster Border Convergence due to faster mapping change updates
- Traffic Path Optimization with Dynamic Default Border
- Backup Internet Option
- Automated route leaking using LISP Extranet

Cisco SD-Access Provision

Border Node Selection

Internal Border (N)
(Rest of Company)

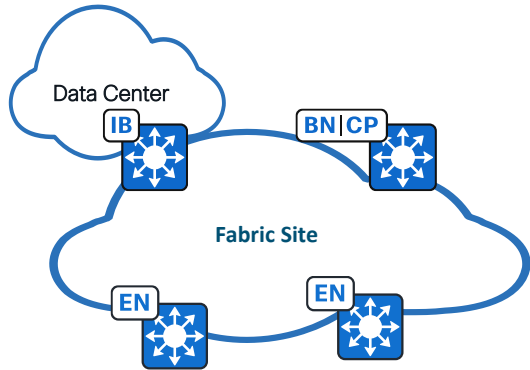

F-FIAB1.demo.local

Layer 3 Handoff Layer 2 Handoff

Enable Layer-3 Handoff

Local Autonomous Number

Default to all virtual networks ⓘ

+ Add Transit/Peer Site

External Border (4 Max)
(Outside)

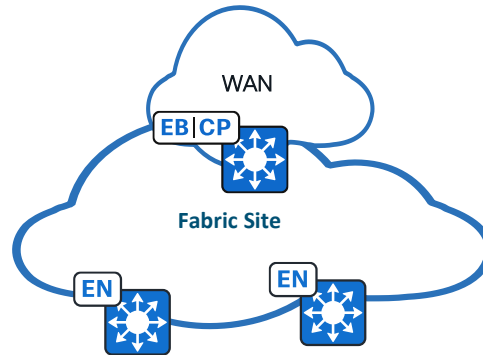

F-FIAB1.demo.local

Layer 3 Handoff Layer 2 Handoff

Enable Layer-3 Handoff

Local Autonomous Number

Default to all virtual networks ⓘ

Do not import external routes ⓘ

+ Add Transit/Peer Site

Internal + External Border (4 Max)
(Anywhere)

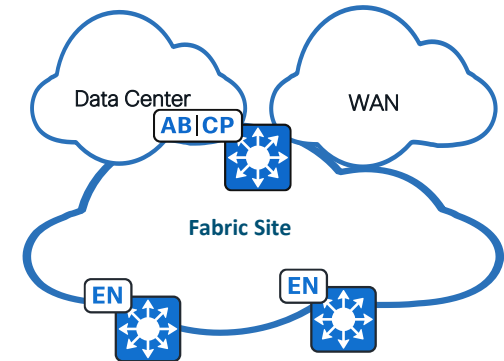

F-FIAB1.demo.local

Layer 3 Handoff Layer 2 Handoff

Enable Layer-3 Handoff

Local Autonomous Number

Default to all virtual networks ⓘ

Do not import external routes ⓘ

+ Add Transit/Peer Site

Cisco DNA Center Provision Authentication Template

Last updated: 4:28 PM [Refresh](#)

🔍 Filter

🔍 Find

Name ▾	Type
Closed Authentication	Closed Authentication
Low Impact	Low Impact
Open Authentication	Open Authentication

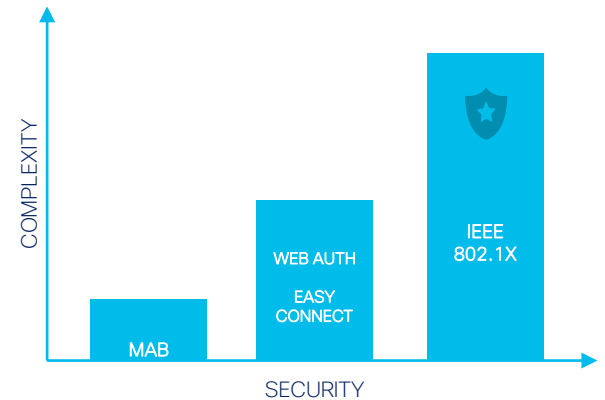
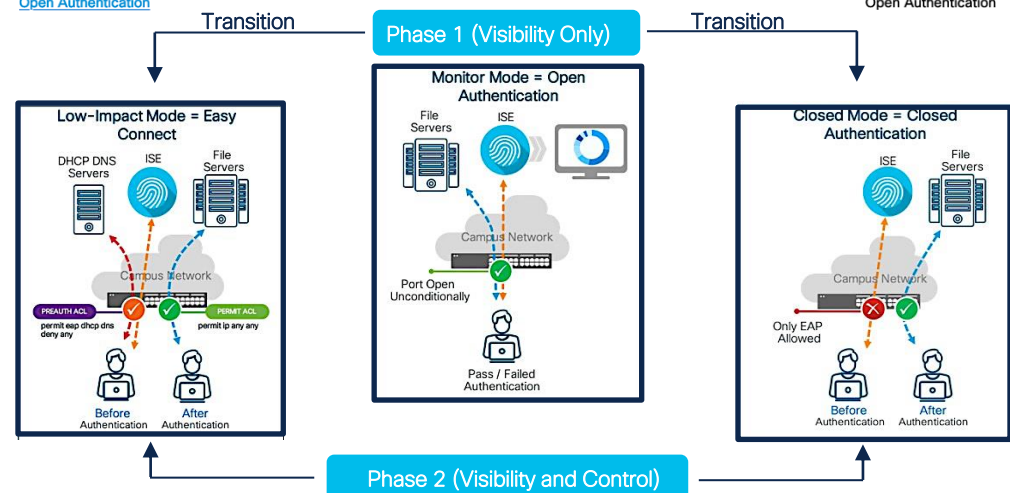

Cisco DNA Center Provision

Closed Authentication Template

Closed Authentication

Deployment Mode: Open Closed

First Authentication Order: 802.1x MAC Auth Bypass(MAB)

802.1x to MAB Fallback: (3 to 14)

Wake on LAN: Yes No

Number of Hosts: Single Unlimited

Authentication Timer Settings

Multi-Auth Host Mode

Multi-Domain Host Mode

Cancel

Submit

CLI's pushed with change in Fallback Timers

```
dot1x timeout tx-period 7  
dot1x max-reauth-req 2
```

Easy Connect

Deployment Mode: Open Closed

First Authentication Order: 802.1x MAC Auth Bypass(MAB)

802.1x to MAB Fallback: (3 to 120)

Wake on LAN: Yes No

Number of Hosts: Single Unlimited

Pre-Auth Access Control (Low Impact Mode)

Implicit Action

Deny



Name

IPV4_PRE_AUTH_ACL

Description (Optional)

Contracts

Action Protocol Port

Action	Protocol	Port	
permit	udp	bootpc	Delete
permit	udp	domain	Delete

Cisco SD-Access Architecture

Current Topology Migration Options

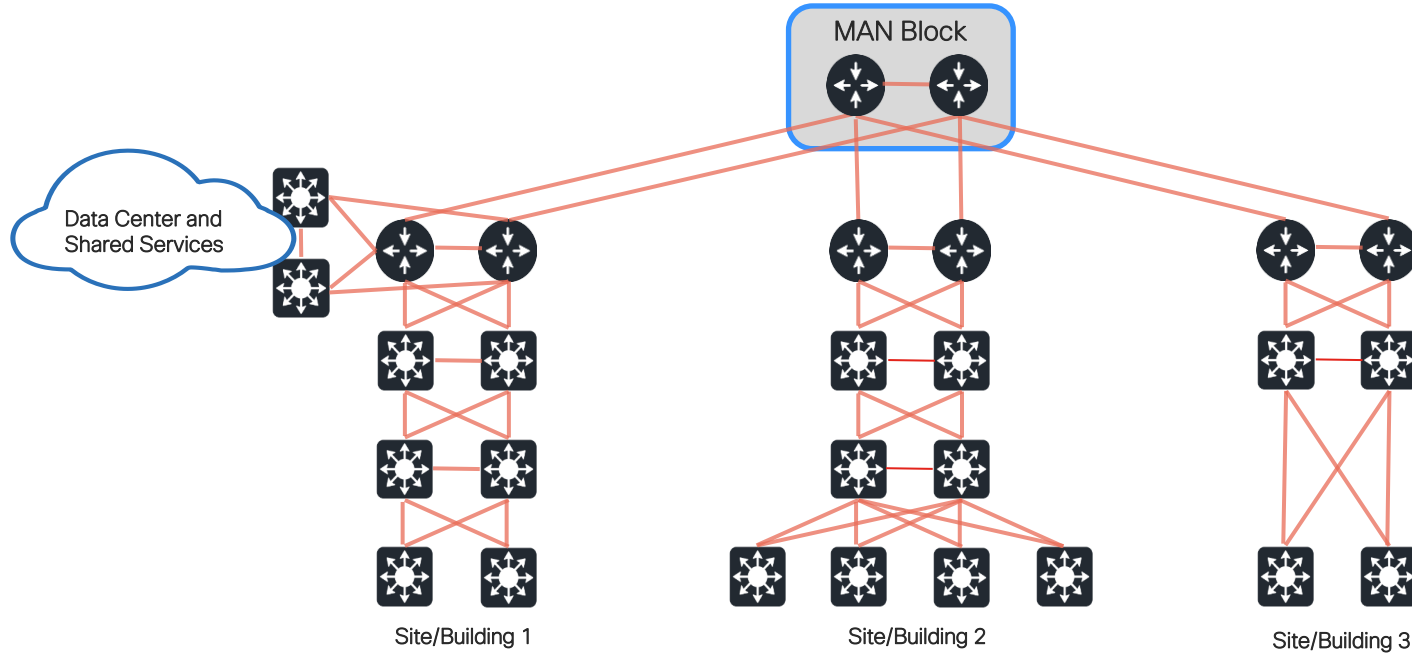

Cisco SD-Access Architecture

Single-Site Architecture

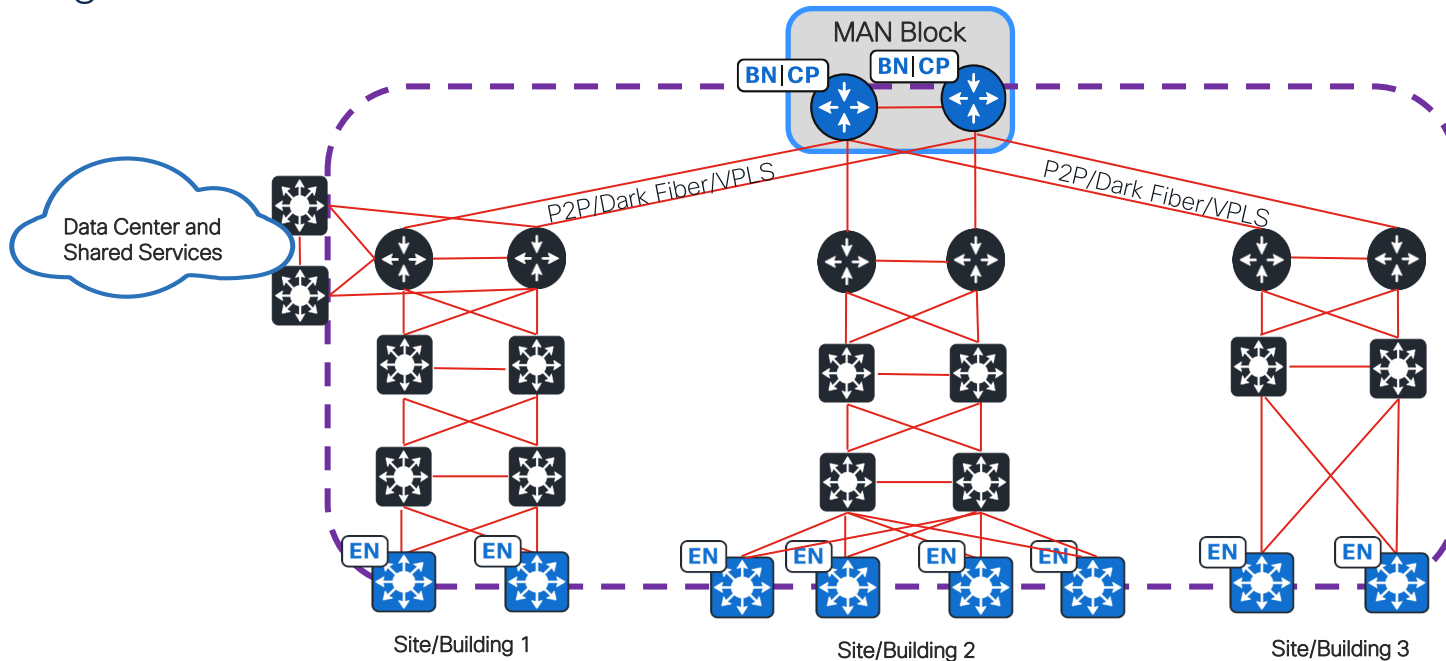

Challenges with Single Site Architecture

- One Subnet available across all buildings/Sites
- One Big Failure Domain
- Scale Limitations – IP Pools supported per site or Border/Control plane Scale

SD-Access Fabric Zones

Use Case

- Before 2.2.3.x, the provisioning scope of an IP Pool was the whole fabric site. For security and/or better fabric site scaling, some customers require granular control of IP Pool provisioning scope.

Details

- SD-Access Fabric Zones are *child sites* of a parent fabric site.
- Edge nodes (EN, EX, PEN) are added to Fabric Zones.
- L3VNs and IP pools are added and provisioned to one or more Fabric Zones.

Considerations

- L3VNs and IP Pools must be assigned to the parent fabric site before assigning to one or more Fabric Zone.
- Only edge nodes (EN, EX, PEN) can be provisioned to a Fabric Zone. Collocated fabric roles (e.g., EN+B, EN + Embedded WLC, etc.) cannot be provisioned to a Fabric Zone.
- EX/PEN must be in same Fabric Zone as parent EN.

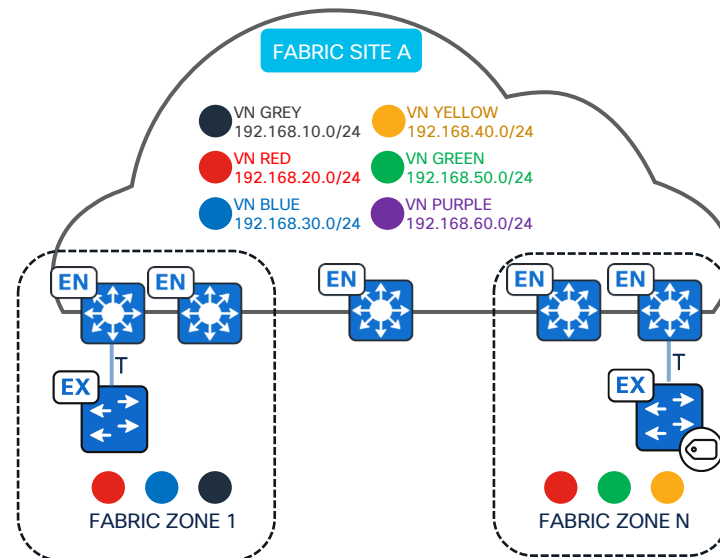

SD-Access Fabric

L3/L2 Overlays

Layer 3 Overlay Stretched Subnets

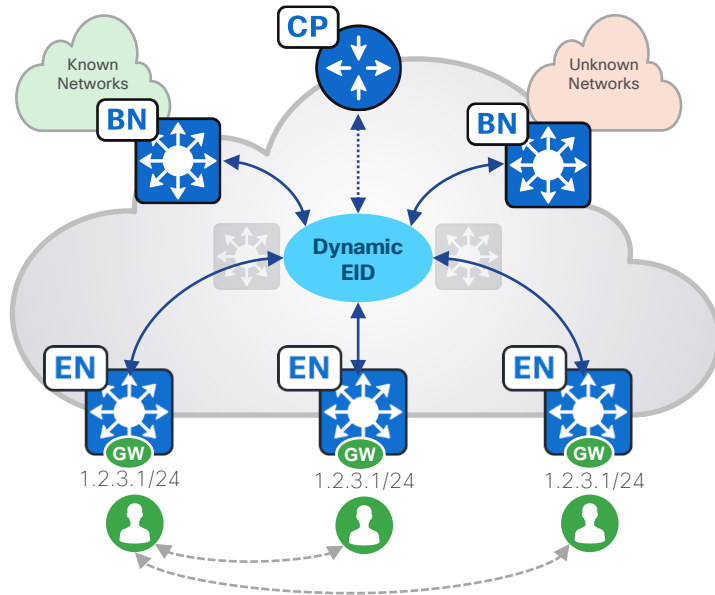

Layer 2 Overlay / GW outside Fabric

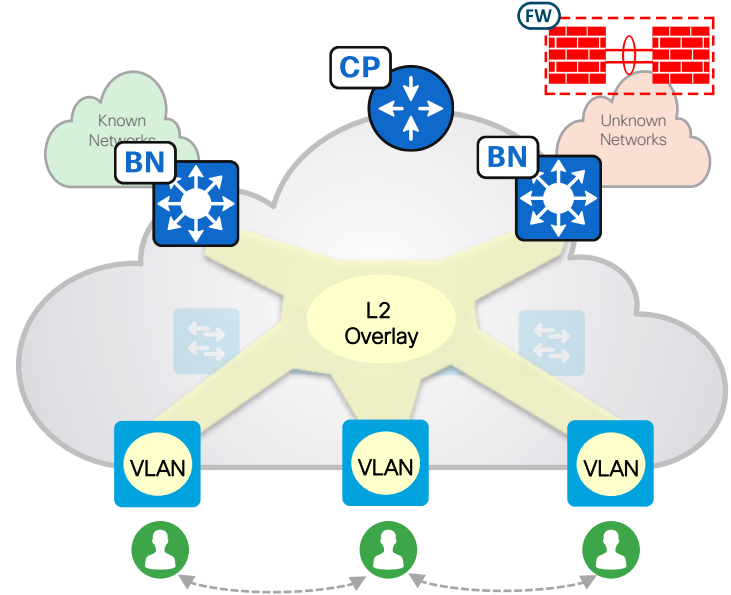

SD-Access Fabric

Border Handoff with Route Leaking

Traditional Route Leaking

```

ip vrf A
rd 1:4099
route-target export 1:4099
route-target import 1:4099
route-target import 1:4097
!
ip vrf B
rd 1:4098
route-target export 1:4100
route-target import 1:4100
route-target import 1:4097
!
ip vrf GLOBAL
rd 1:4097
route-target export 1:4097
route-target import 1:4097
route-target export 1:4099
route-target export 1:4100

```

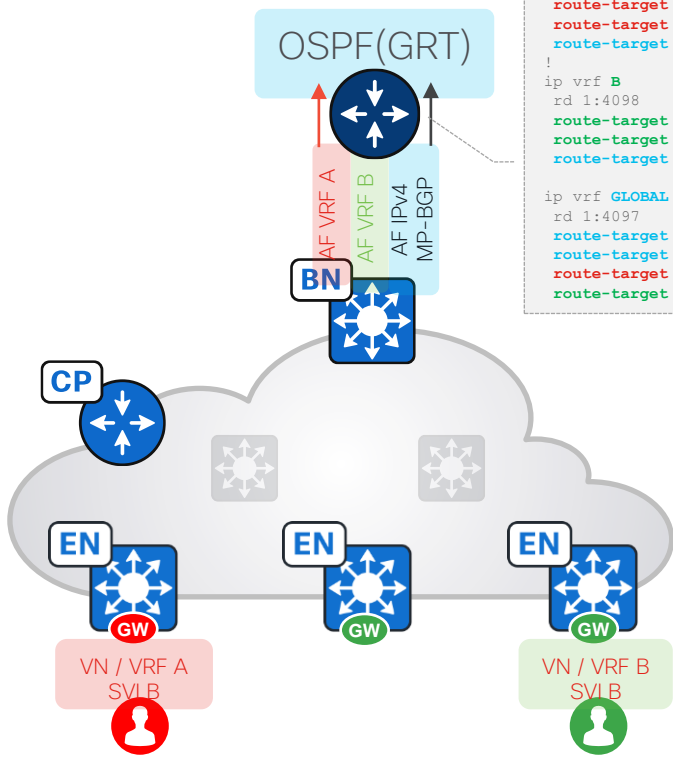

LISP Extranet

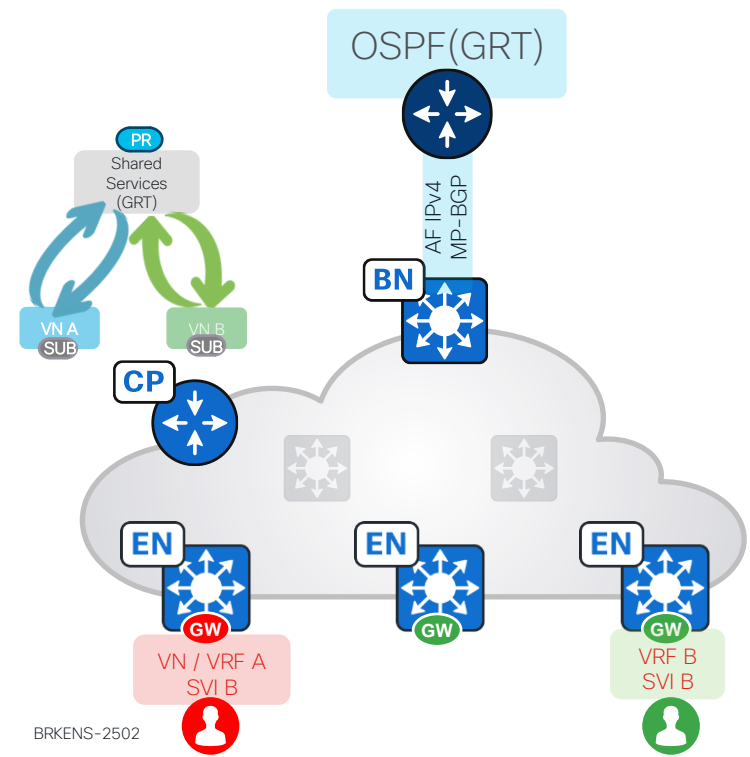

Cisco SD-Access Architecture

Multisite Architecture with IP TRANSIT

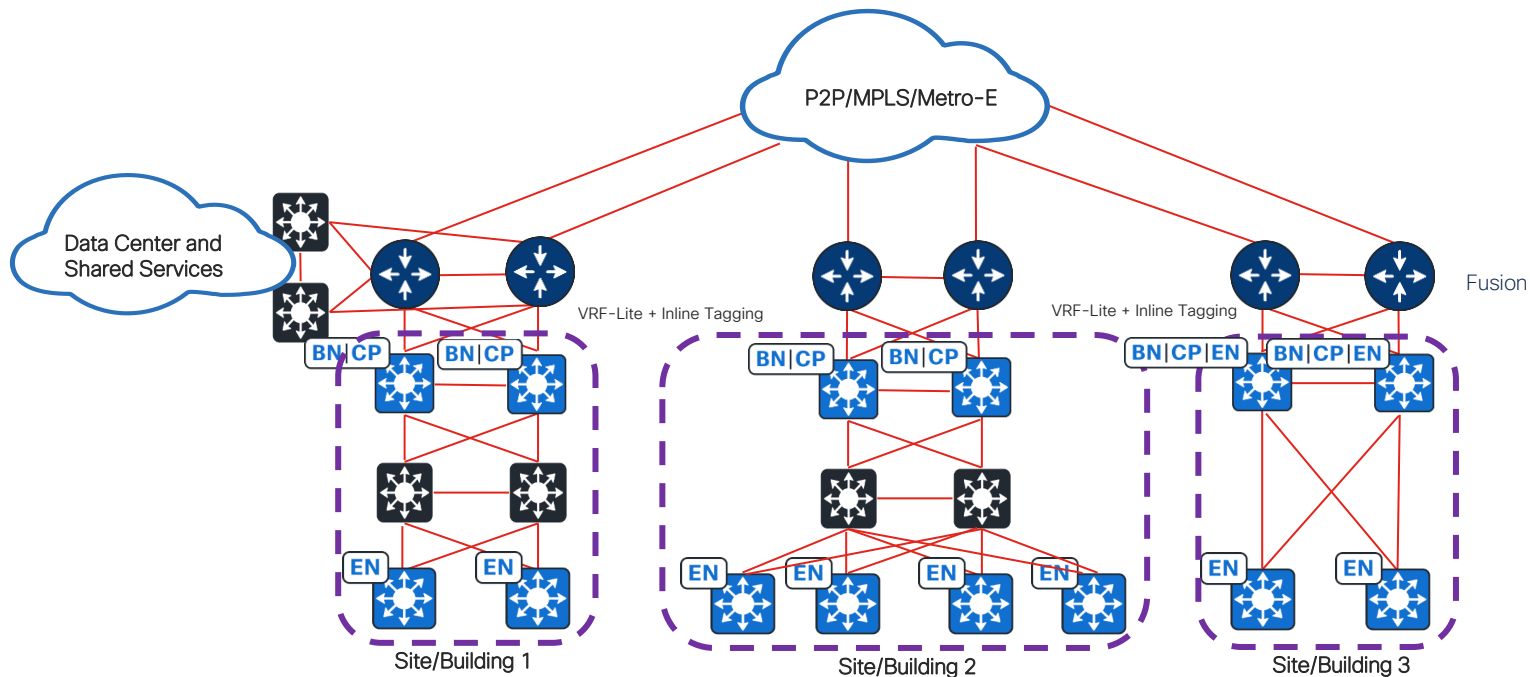

Challenges with Multisite IP Transit

- No End to End Segmentation.
- Fusion Routers at every site
- No Automation on Fusion device

Cisco SD-Access Architecture

Multisite Architecture with SD-Access Transit

Pre-Requisite with SD-Access Transit

- Higher MTU Support on WAN
- *Else use TCP Adjust-MSS

Benefits with SD-Access Transit:

- End to End Segmentation.
- Automated configuration
- No Fusion device at every site

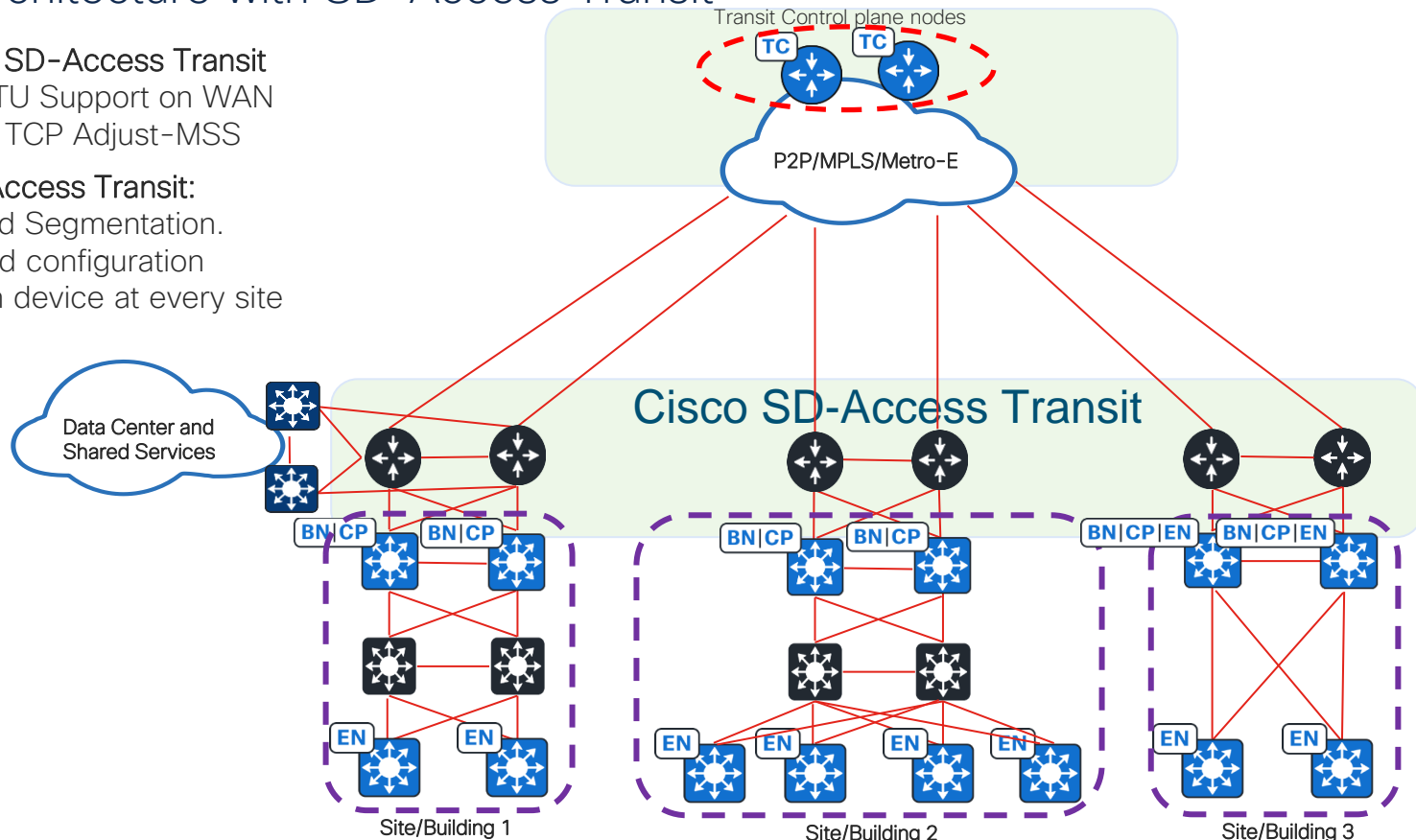

Cisco SD-Access Deployment

Multisite Deployment with SD-Access Transit

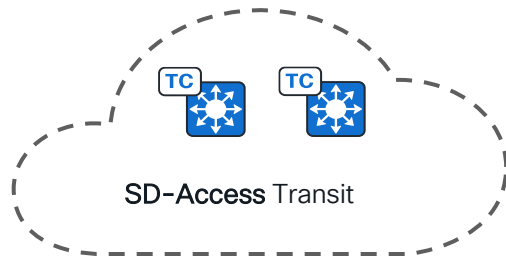

SD-Access Transit is a native solution carrying VN and SGT between Fabric sites.

Key Considerations:

- Higher MTU support

- Transit Control Plane nodes are **dedicated devices** with IP reachability to every fabric site's Border nodes
- Transit Control Plane nodes is **not required to be in data forwarding path**
- Transit Control Plane nodes maintains aggregate prefixes of all Fabric sites
- Fabric site Border node should be either External or Anywhere border type to connect to SD-Access Transit.
- SD-Access Transit can be deployed with LISP-BGP or LISP Pub/Sub

Cisco SD-Access Multisite

Cisco IP Transit Design 1 - IP Transit with End to End Segmentation

- ✓ WAN is P2P or Metro-E with JUMBO MTU support
- ✓ End to End Macro and Micro Segmentation across Fabric sites.
- ✓ With the use of CMD/Inline Tagging from Border device
- ✓ Need additional TrustSec hardware which can support CMD

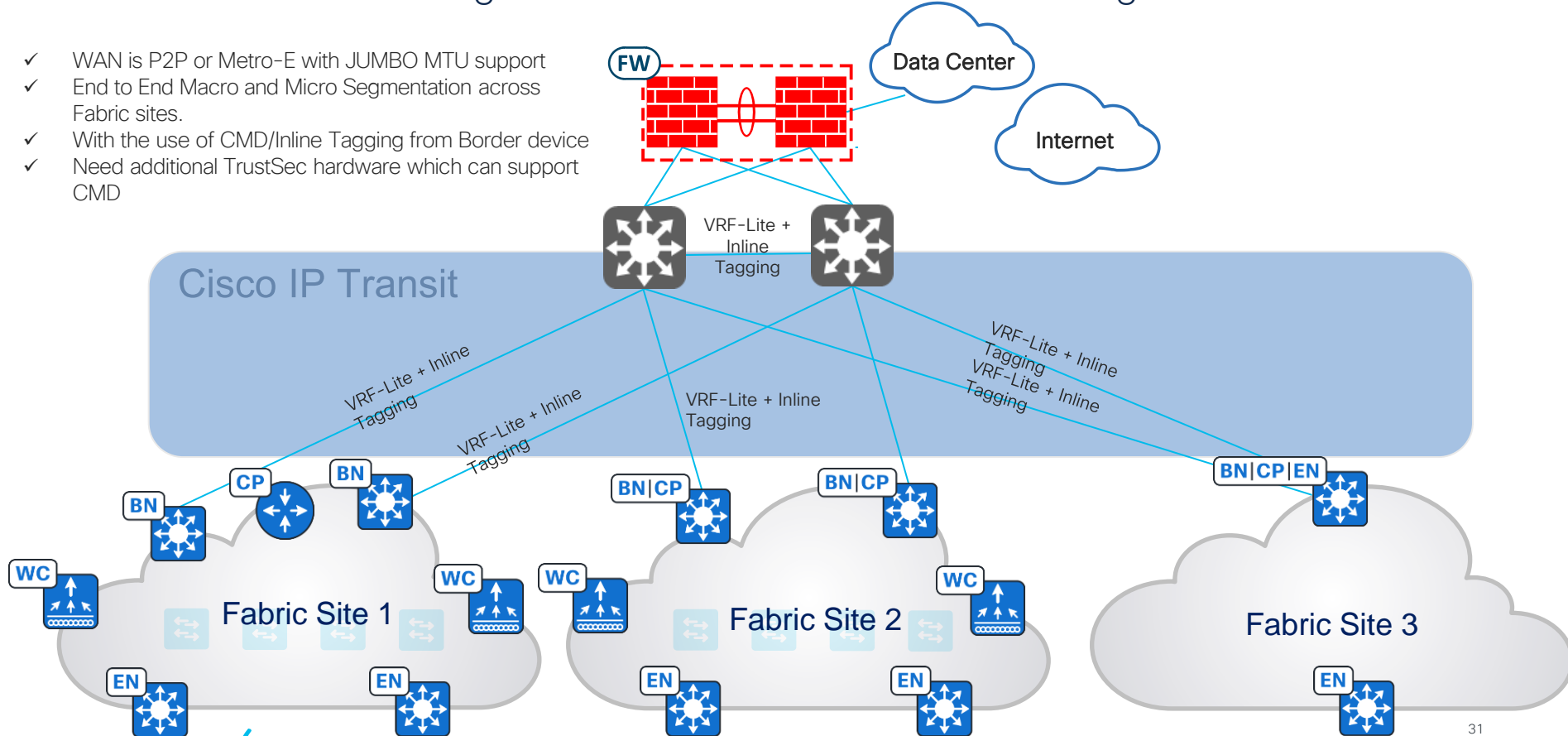

Cisco SD-Access Multisite

Cisco SD-Access Transit Design 1

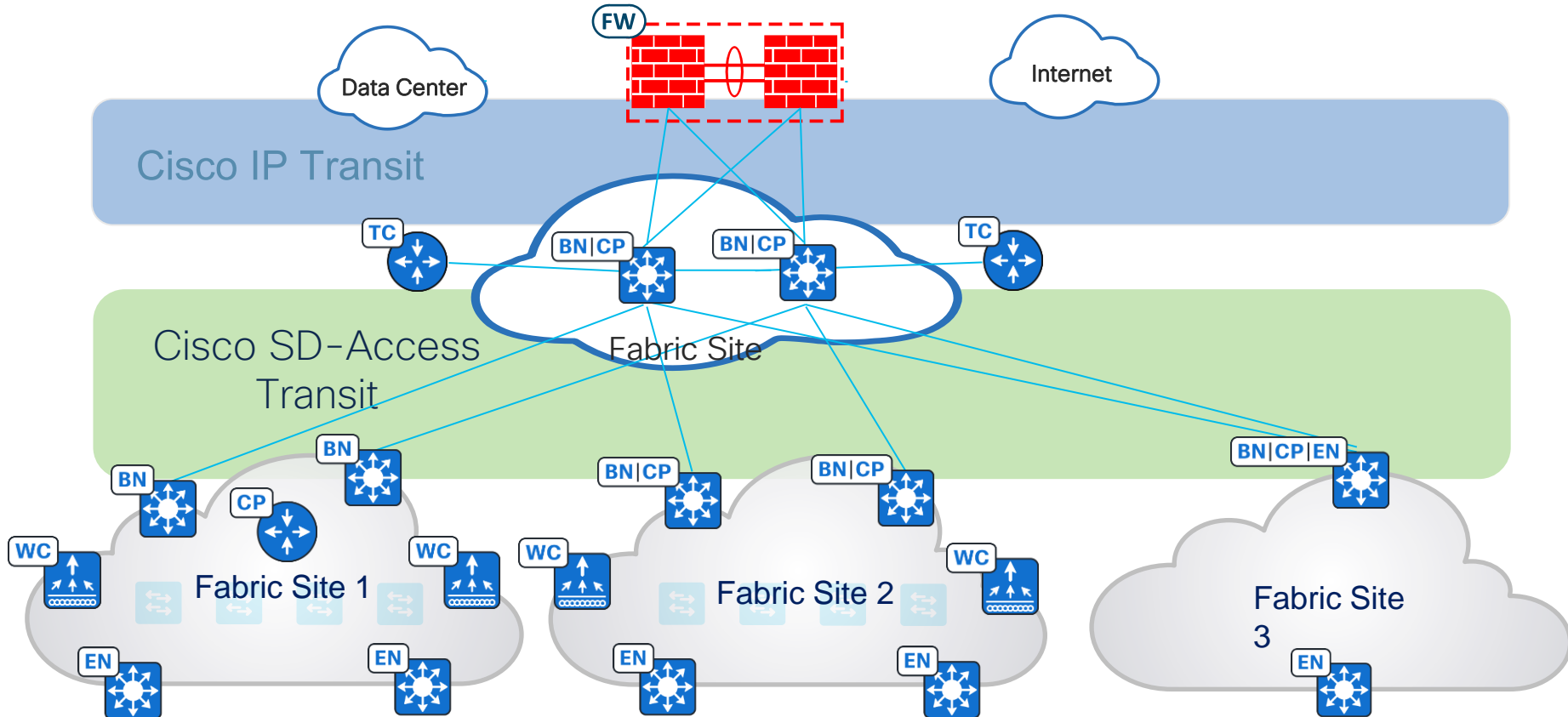

Cisco SD-Access Multisite

Transit Design across Cisco DNA Center Clusters

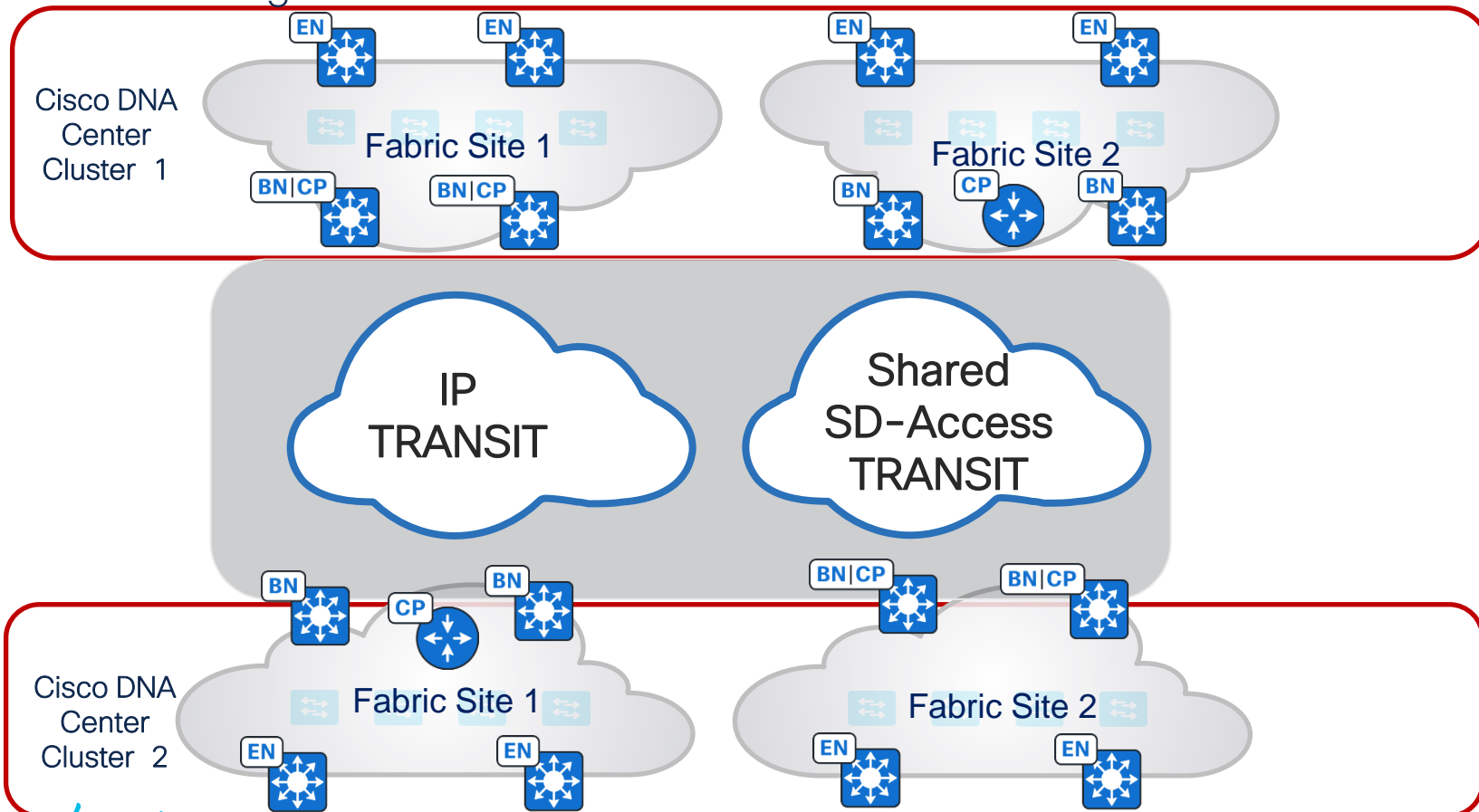

Cisco SD-Access Multisite

Transit Design across Cisco DNA Center Clusters

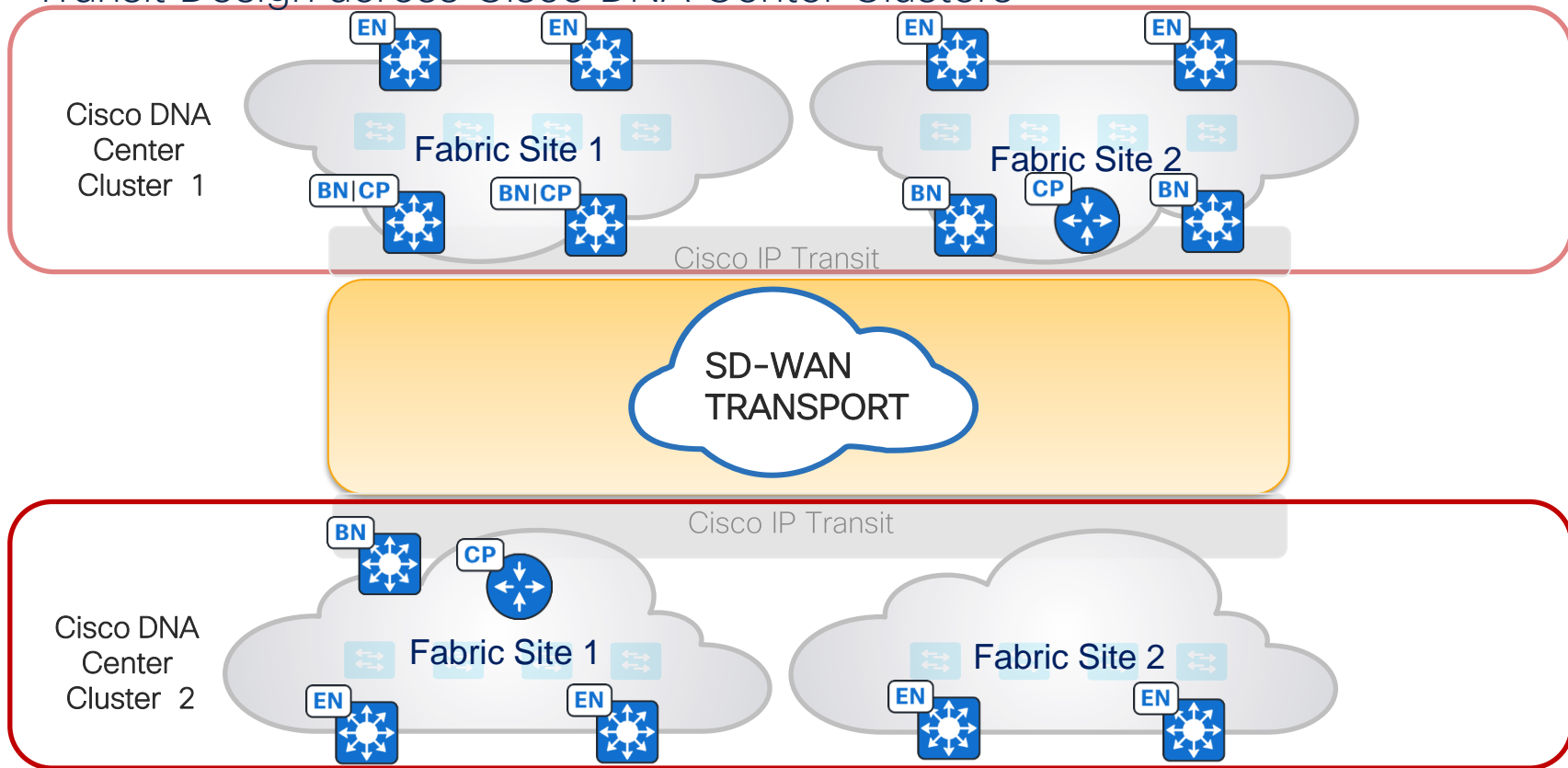

Cisco SD-Access Multicast

Supported Modes(Overlay)	: ASM, SSM
RP Overlay Placement (ASM)	: Inside/Outside Fabric
Source/Receiver Placement	: Inside/Outside Fabric
Multicast Configuration	: Automated by Cisco DNA Center
Per VN RP support	: Supported
Multi-site with SD-A Transit	: Supported with LISP PUB/SUB
Multiple RP per VN	: Supported
Group to RP Mappings	: Supported
Concurrent ASM/SSM	: Supported

Cisco SD-Access Multicast

Fabric Multicast Deployment Modes

Head-End Replication	Native Multicast
No Underlay Multicast	Underlay Multicast required
Preferred for lesser Edge nodes in FS	Preferred option for Large number of Edge nodes in FS
Replication Load on Head-End device	Reduces replication Load at the Head-End
V4 and V6 support	No V6 support

SD-Access Wireless Connectivity

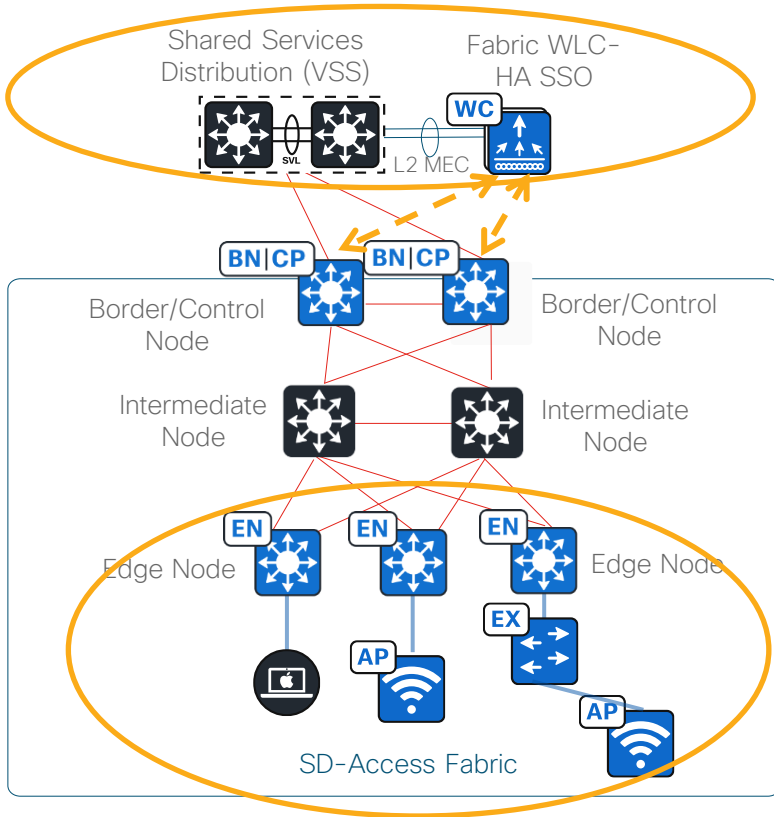

- WLC typically connect to a “shared services” Distribution Block
 - VSS/Stack is the preferred topology
 - Management IP address in Global Routing Table
 - Specific route to advertise WLC’s IP in the underlay
- WLC can talk to only #2 Enterprise CP nodes
- Access Points connect to Fabric Edge
 - APs reside in INFRA_VN (GRT) and form CAPWAP connection to WLC. No need for VRF leaking
 - AP can be connected to an Edge/Extended node
 - APs are connected in Local mode

Cisco SD-Access Wireless

Deployment types

Supported Platforms

AP Mode

Control-Plane Node support

: FEW , OTT , Mixed Mode

: C9800, EWC,3504,5520,8540

: Local, Flex*

: 2(AireOS) , 8(C9800)*

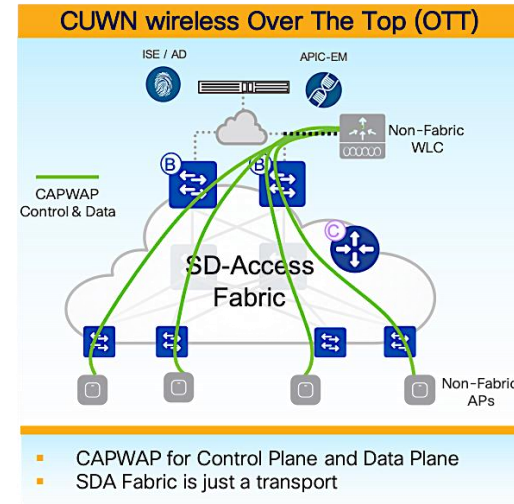
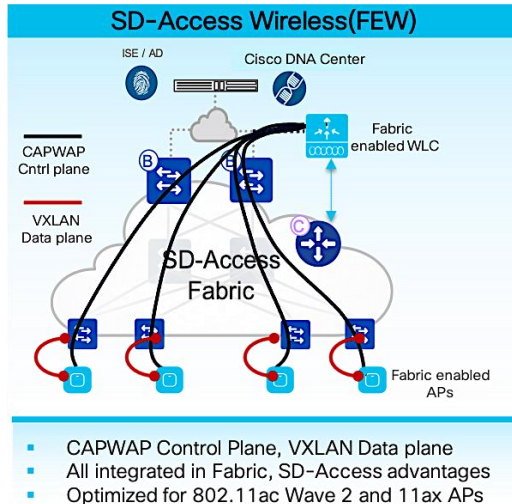

SD-Access Wireless Design Best Practices

SVL in Fabric Topology Examples

Device Family	BP	CP	EN	BN+CP	FIAB	FIAB+eWLC	SVL as Seed
C9400/C9500	Yes	Yes	Yes	Yes	Yes	Yes	Yes
C9600	Yes	Yes	No	Yes	No	No	Yes

Fabric AP to SVL Edge Node

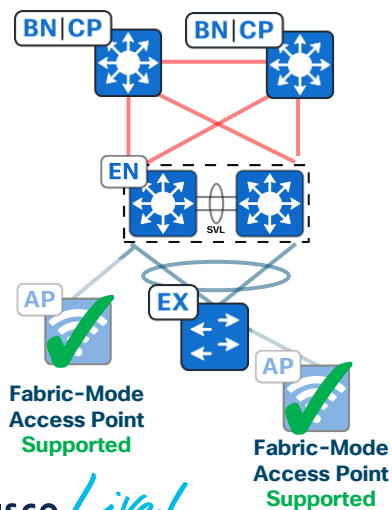

Fabric AP to EX/PEN

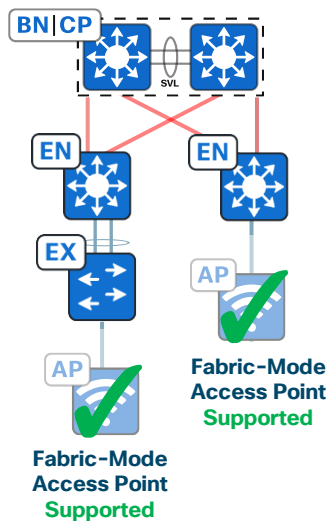

Embedded Wireless support on SVL*

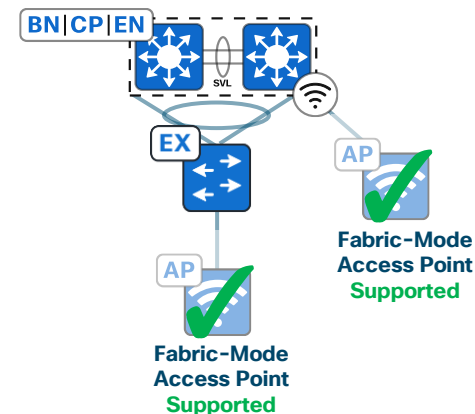

* - Catalyst 9400 and 9500

SD-Access Wireless Design Best Practices

Fabric Wireless Recommendations

SD-Access – WLC Scale

Platform	Number of APs	Number of Clients
Aironet 3504	150	3,000
Aironet 5520	1,500	20,000
Aironet 8540	6,000	40,000
Catalyst 9800L	250	5,000
Catalyst 9800-CL (4 CPUs / 8 GB RAM)	1,000	10,000
Catalyst 9800-40	2,000	32,000
Catalyst 9800-CL (6 CPUs / 16 GB RAM)	3,000	32,000
Catalyst 9800-80	6,000	64,000
Catalyst 9800-CL (10 CPUs / 32 GB RAM)	6,000	64,000

SD-Access – Embedded Wireless

Platform	Number of APs	Number of Clients
Catalyst 9200/L	Not Supported	Not Supported
Catalyst 9300/L	50	1000
Catalyst 9300 (Single Switch)	100	2000
Catalyst 9300 (Switch Stack)	200	4000
Catalyst 9400/9500/9500H	200	4000

SD-Access Wireless Design Best Practices

SD-Access Wireless – N+1 HA vs SSO

DNA Center: 2.1.2.0

Stateless Redundancy with N+1 HA

Redundancy
Comparison

Stateful Redundancy with SSO

- WLCs remain independent of each other. Cisco DNA Center and SD-Access fabric sees them as two separate WLCs.
- For each location there is a primary and a secondary WLC.
- Both WLCs communicate with the control plane nodes.
- In a failover event, the CAPWAP tunnel is broken between AP and Primary WLC and is reinitiated with the Secondary WLC.
- APs and clients move to the Secondary WLC.
- AP rolling upgrade support(DNA Center 2.1.2.0 onwards)

- WLC SSO is seen as a single entity.
- Only active WLC communicates with the control plane nodes.
- APs and clients stay connected during a failover event.
- In a failover event, the new Active WLC will bulk update the control plane node regarding the wireless hosts.
- For Embedded Wireless on Catalyst 9000 switches, SSO is achieved through hardware stacking on Catalyst 9300/L switches and through redundant supervisors on Catalyst 9400 switches and Catalyst 9500 SVL

Cisco SD-Access Wireless

Wireless Guest Design - Dedicated Virtual Network

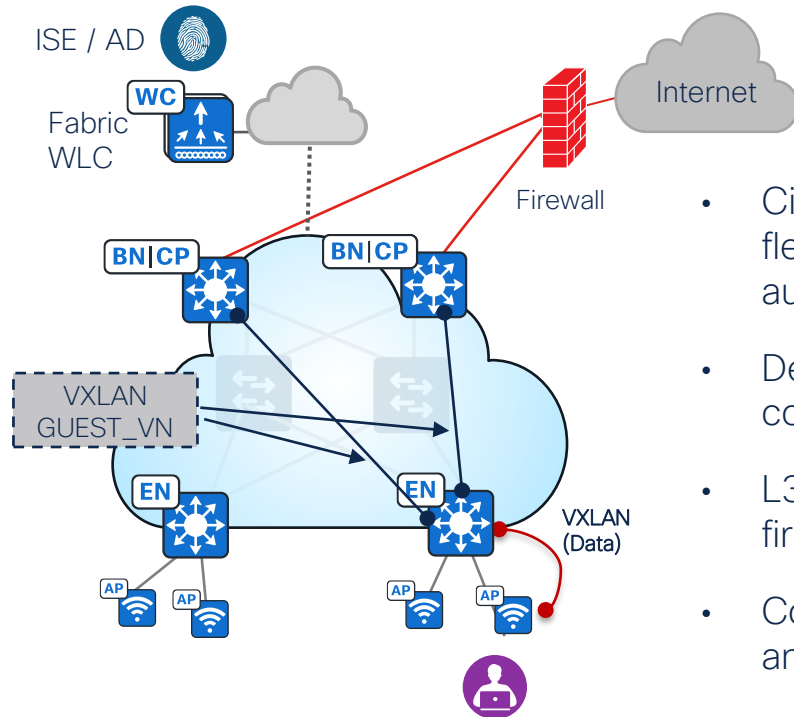

- Cisco DNA Center Guest-SSID workflow provides flexibility to create custom Guest portal with ISE authorization policies.
- Dedicated Virtual Networks for segmentation provides control plane and data plane isolation
- L3 Handoff with BGP peering between Border and firewall.
- Consistent network and policy deployment for wired and wireless infrastructure

Cisco SD-Access Wireless

Wireless Guest Design - Dedicated Virtual Network with MSRB

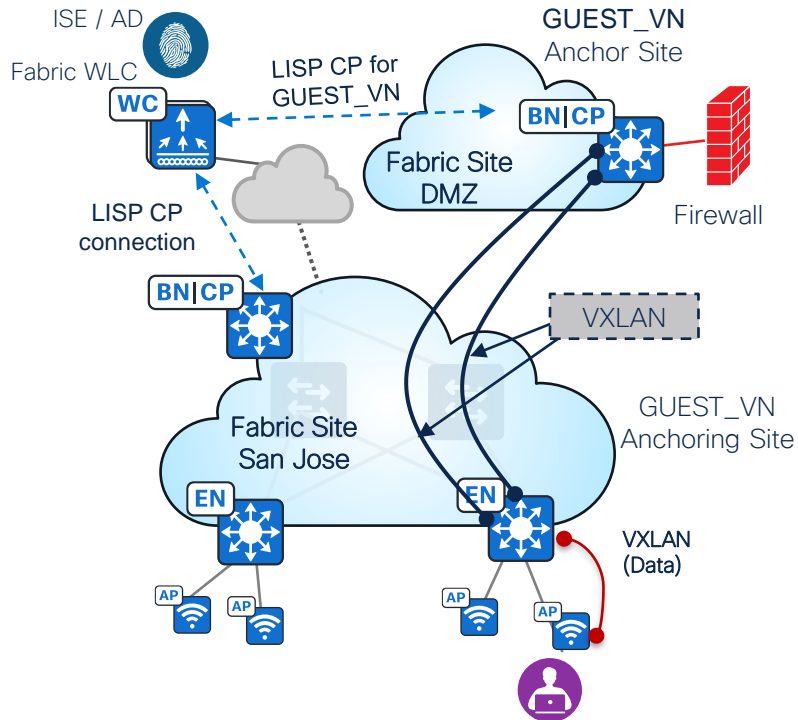

- Multisite Remote Border (MSRB) allows a Virtual Network to be anchored to a different fabric site's Border, Control Plane nodes providing traffic egress point flexibility.
- Edge node (Anchoring site) encapsulates VXLAN with destination as remote-site Border (Anchor site) for the VN.
- VXLAN cannot be fragmented, higher MTU must be supported across the sites
- Catalyst 9800 can support up to 8 Control Plane node pairs.
- AireOS WLCs can support maximum 2x Control Plane node pairs

Cisco ISE Use Cases in SD-Access

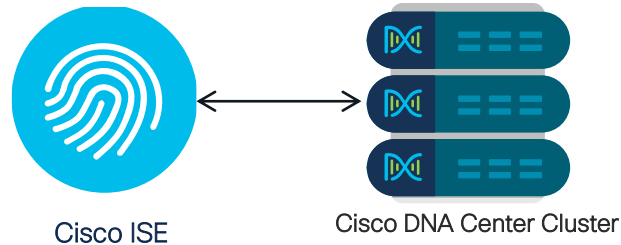

Guest Access

Guest network automation

Host On-boarding

User authentication

Group Based Policies

SDA Segmentation

Assurance

Client 360

Device Administration

TACACS

Asset Visibility

Everything & Everyone on
Network

Policy Analytics

Group to Group Interaction
with automated policy

Security Ecosystem

Integration

Context Sharing

CISCO *Live!*

Cisco DNA Center Settings

Cisco ISE + Load Balancer

The screenshot shows the Cisco DNA Center interface. The main content area is titled "Authentication and Policy Servers" and contains a table of servers. A modal window titled "Edit ISE server" is open on the right, showing fields for Server IP Address, Shared Secret, Username, Password, FQDN, Subscriber Name, and Virtual IP Address(es). A blue callout box points to the Virtual IP Address field, which contains the value "172.25.73.240".

Settings / External Services

Authentication and Policy Servers

Use this form to specify the servers that authenticate Cisco DNA Center users. Cisco Identity Services Engine (ISE) servers can also supply policy and user information.

[Add](#) [Export](#)

IP Address	Protocol	Type
172.25.73.223	RADIUS_TACACS	ISE

Edit ISE server

Server IP Address
172.25.73.223

Shared Secret

Username*
admin

Password*

FQDN
ISE10-1.demo.local

Subscriber Name
DNAC10

Virtual IP Address(es)
172.25.73.240 [Info](#)

Advanced Settings

[Cancel](#) [Add](#)

Cisco DNA Center Design

ISE as AAA Server for Client and Network

Edit ISE server

Server IP Address
172.25.73.223

Shared Secret

Username*
admin

Password*

FQDN
ISE10-1.demo.local

Subscriber Name
DNAC10

Virtual IP Address(es)

Advanced Settings

Connect to pxGrid

Use Cisco DNA Center Certificate for pxGrid

Protocol
 RADIUS TACACS

Authentication Port
1812

Accounting Port
1813

Port
49

Retries*
3

Timeout (seconds)*
4

Cancel Add

Cisco DNA Center Design - Network Settings

Network Device Credentials IP Address Pools SP Profiles Wireless Telemetry

Find Hierarchy

- Global
 - SITE-A
 - Building 1
 - Floor 1
 - SITE-B
 - SITE-C
 - SITE-D
 - SITE-F
 - SITE-T

Configure AAA, NTP, and Image Distribution (SFTP) servers using the "Add Servers" link. Once devices are discovered, DNA Center will deploy using these settings.

AAA Server

Network Client/Endpoint

NETWORK

Servers: ISE AAA

Protocol: RADIUS TACACS

Network: 172.25.73.223

IP Address (Primary): 192.168.1.225

IP Address (Additional): 192.168.1.226

- PSNs -

- 192.168.1.225
- 172.25.73.225
- 192.168.1.226
- 172.25.73.226

CLIENT/ENDPOINT

Servers: ISE AAA

Protocol: RADIUS TACACS

Client/Endpoint: 172.25.73.223

IP Address (Primary): 192.168.1.225

IP Address (Additional): 192.168.1.226

Change Shared Secret

DHCP Server

Reset Save

CISCO *Live!*

Security Group Tags(SGT)

Classification Mechanism

Dynamic Classification

Static Classification

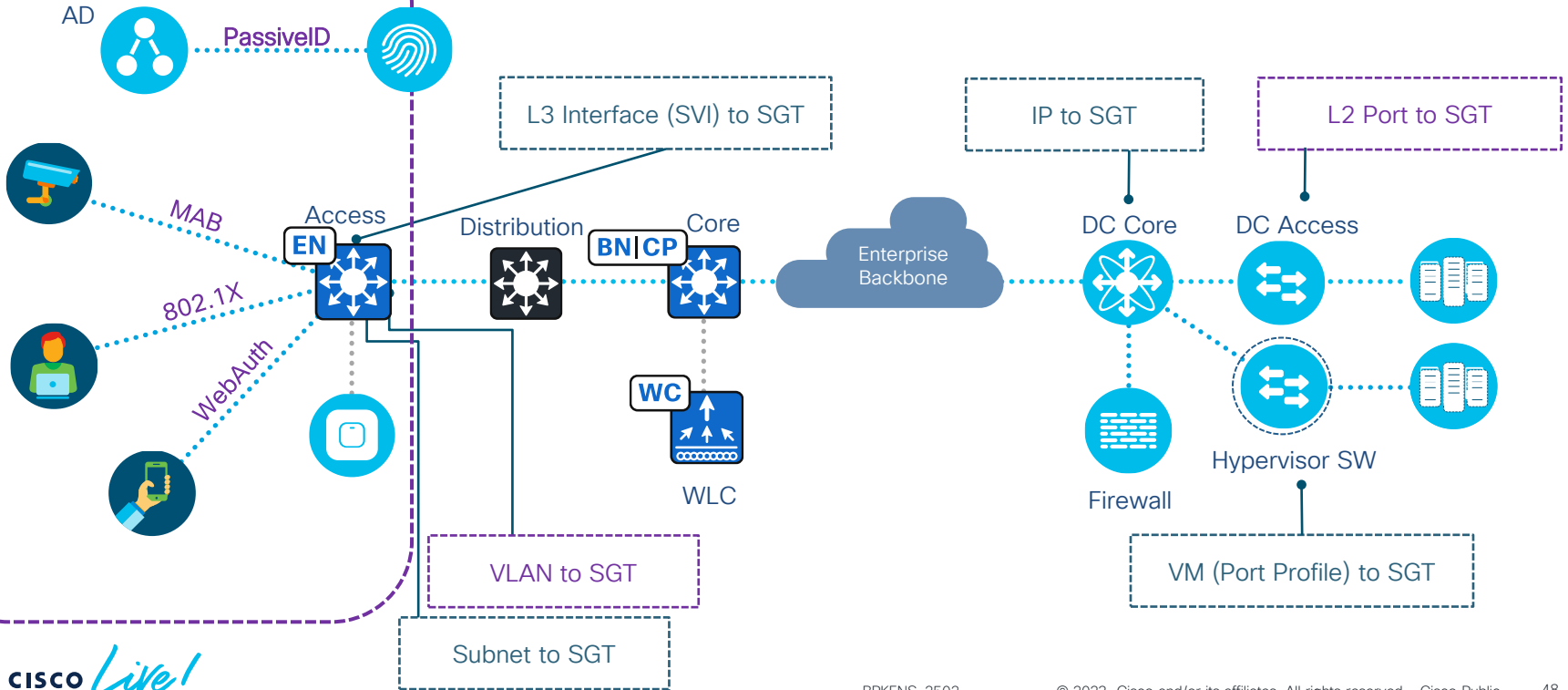

Security Group Tags(SGT)

Propagation Mechanism

Inline Tagging Methods

- **Ethernet Inline Tagging:** (EtherType:0x8909) 16-Bit SGT encapsulated within Cisco Meta Data (CMD) payload.
- **IPSec / L3 Crypto:** Cisco Meta Data (CMD) uses protocol 99, and is inserted to the beginning of the ESP/AH payload.
- **LISP:** SGT (16 bit) insertion in the Nonce field (24 bit)
- **VXLAN:** SGT (16 bit) inserted into Segment ID of VXLAN Header

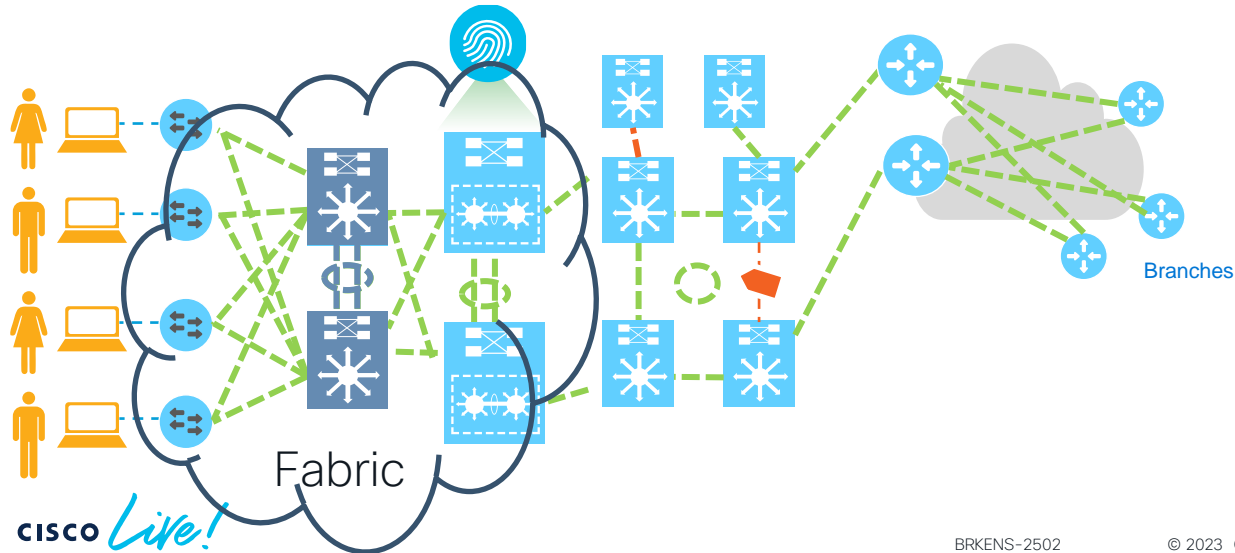

Propagation options

- Cisco MetaData (CMD)
- Ethernet
- MACsec
- IPSec
- DM-VPN
- GET-VPN
- VXLAN

Supporting devices

- Catalyst switches
- WLAN controllers
- Nexus switches
- Integrated Service Routers
- Industrial Ethernet Switches
- ASR 1000
- ASA 5500-x
- Firepower Threat Defense

Cisco DNA Center Policy

Access Contracts Enforcement

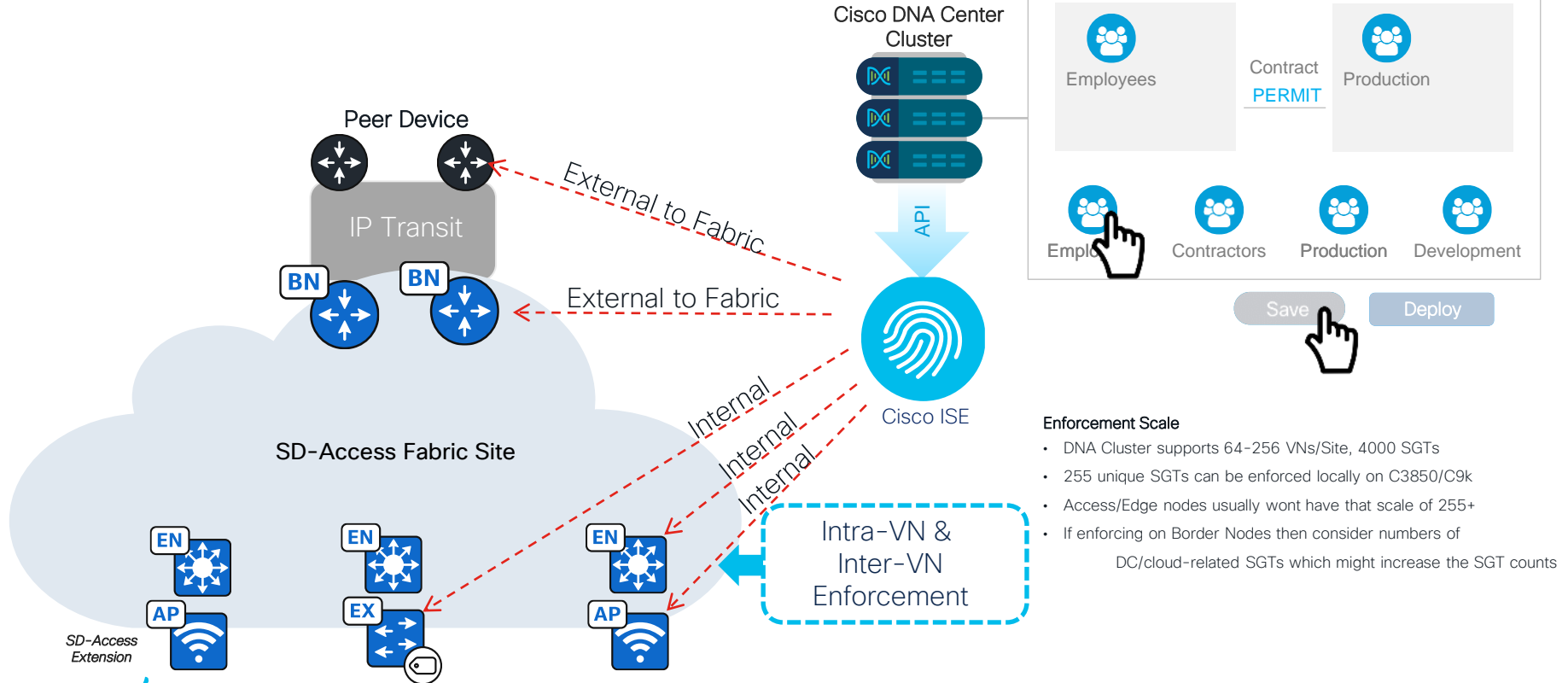

Enforcement Scale

- DNA Cluster supports 64-256 VNs/Site, 4000 SGTs
- 255 unique SGTs can be enforced locally on C3850/C9k
- Access/Edge nodes usually won't have that scale of 255+
- If enforcing on Border Nodes then consider numbers of DC/cloud-related SGTs which might increase the SGT counts

Integrating Multiple Cisco DNA Center with ISE

Option 1

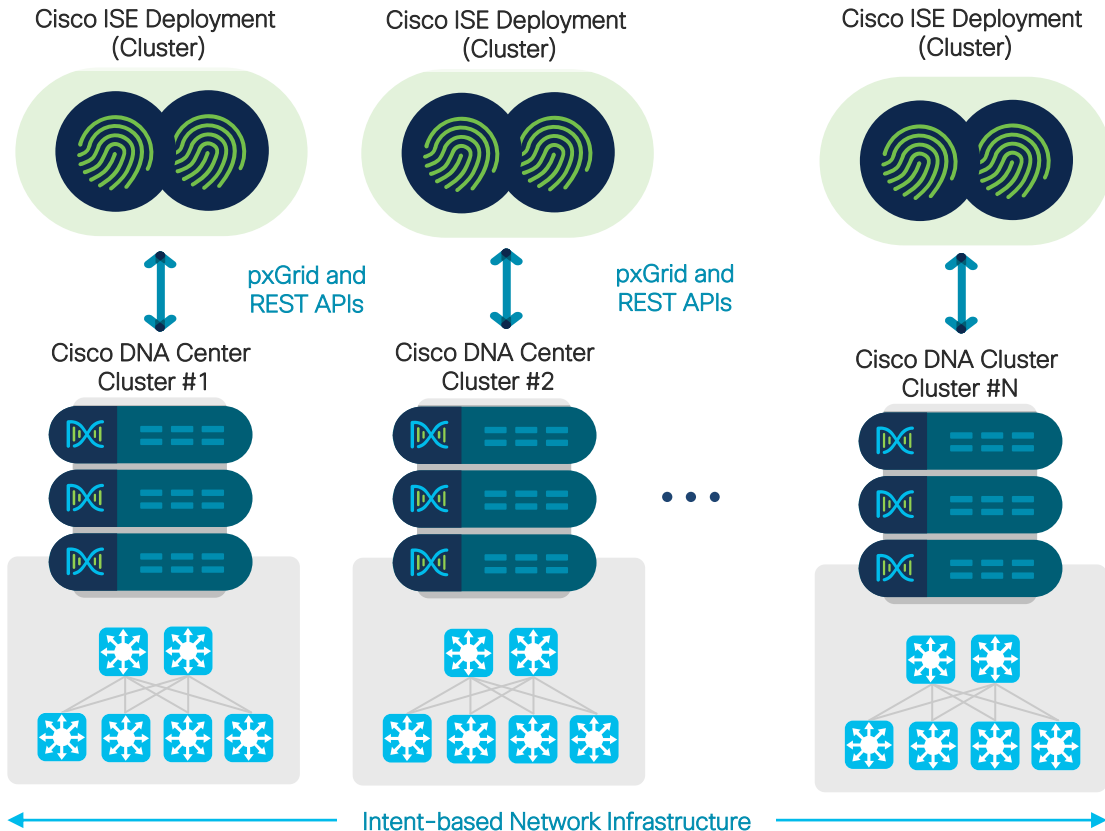

Integrating Multiple Cisco DNA Center with ISE

Option 2*

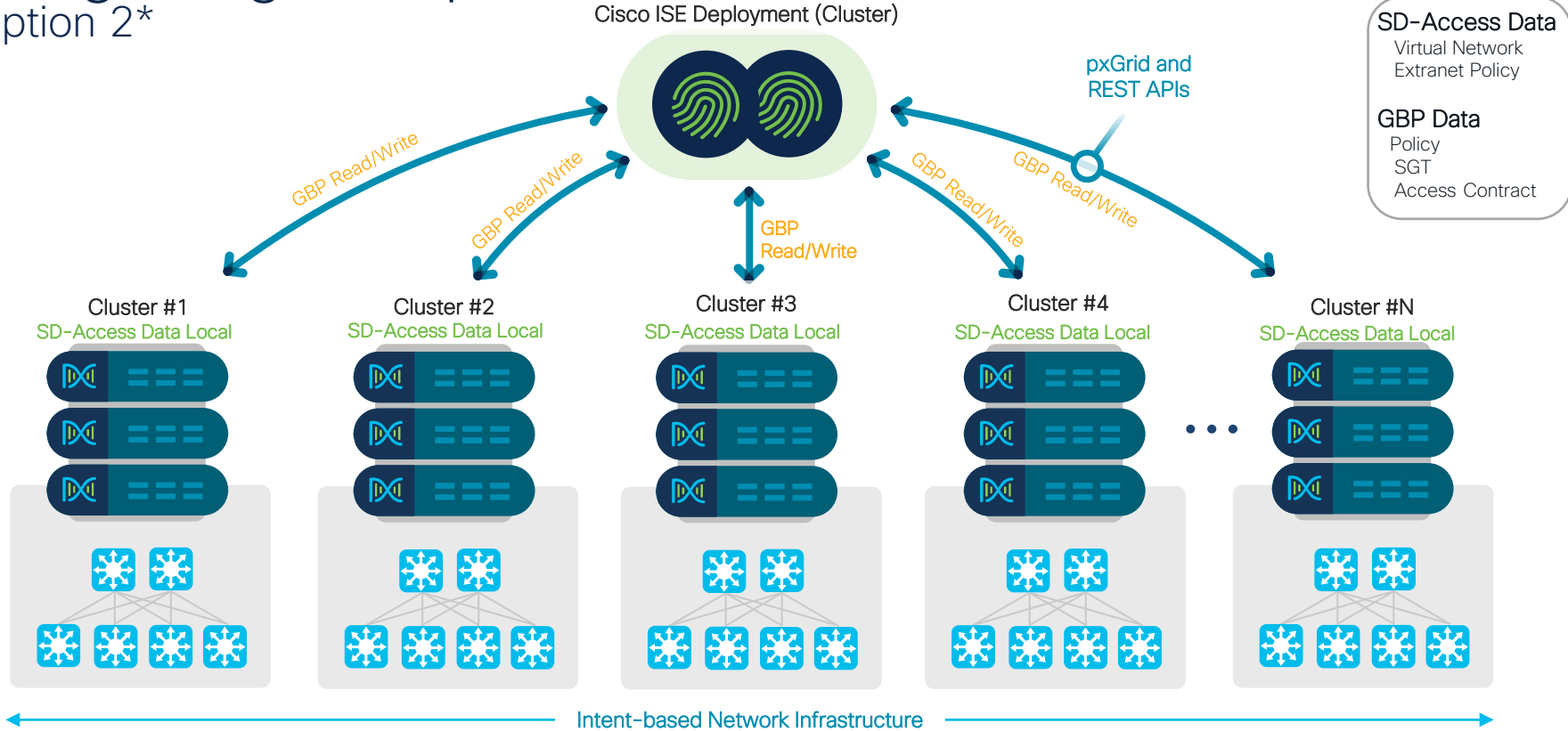

Integrating Multiple Cisco DNA Center with ISE

Option 3- Multiple Cisco DNA Center Solution Overview

Cisco ISE Deployment (Cluster)

N=5 starting
DNA Center: 2.2.3.x

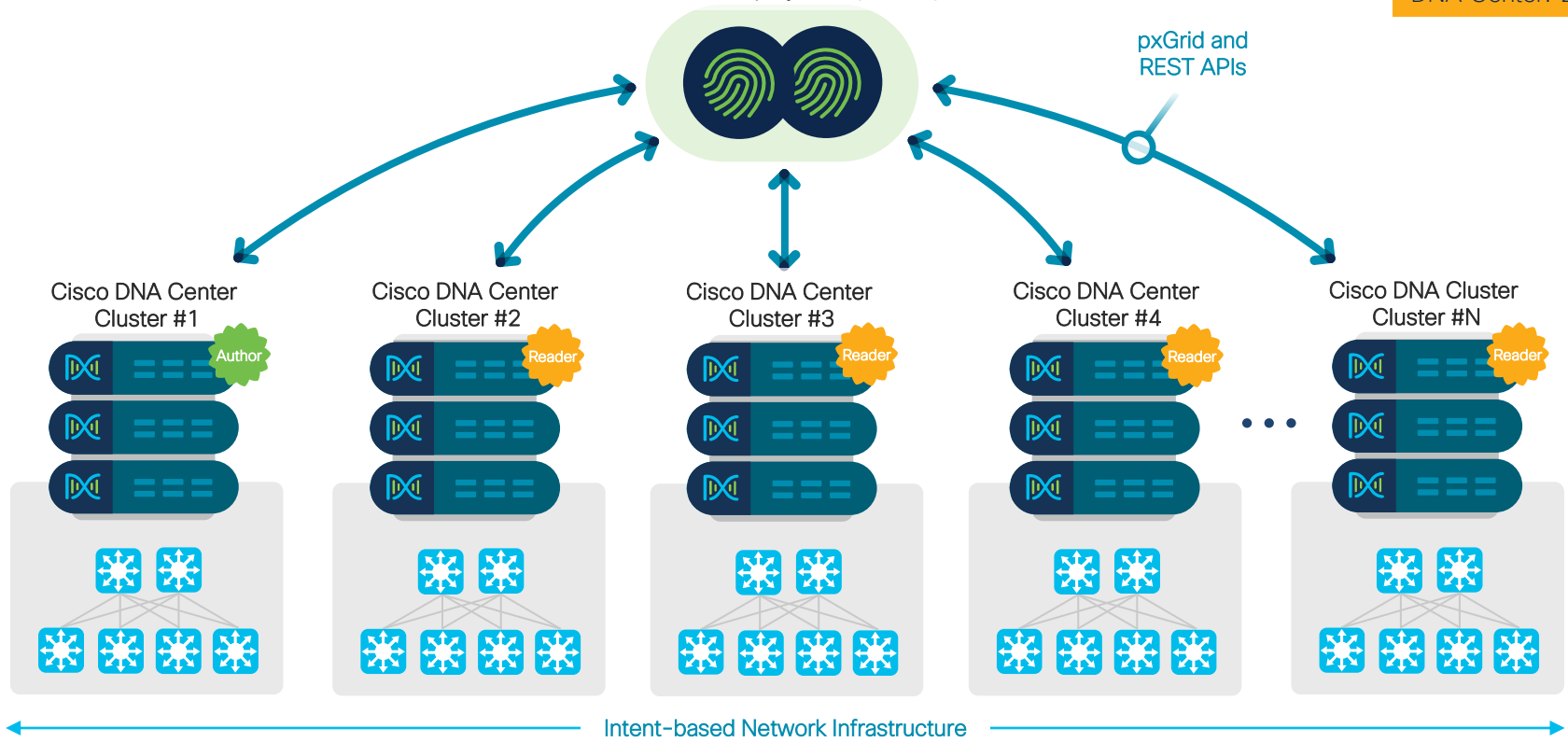

Multiple Cisco DNA Center Use Case

Shared SD-Access Transit

Shared SD-Access Transit starting
DNA Center: 2.2.3.x

4 TCP Node supported Starting
DNA Center : 2.3.3.0

Cisco ISE Deployment (Cluster)

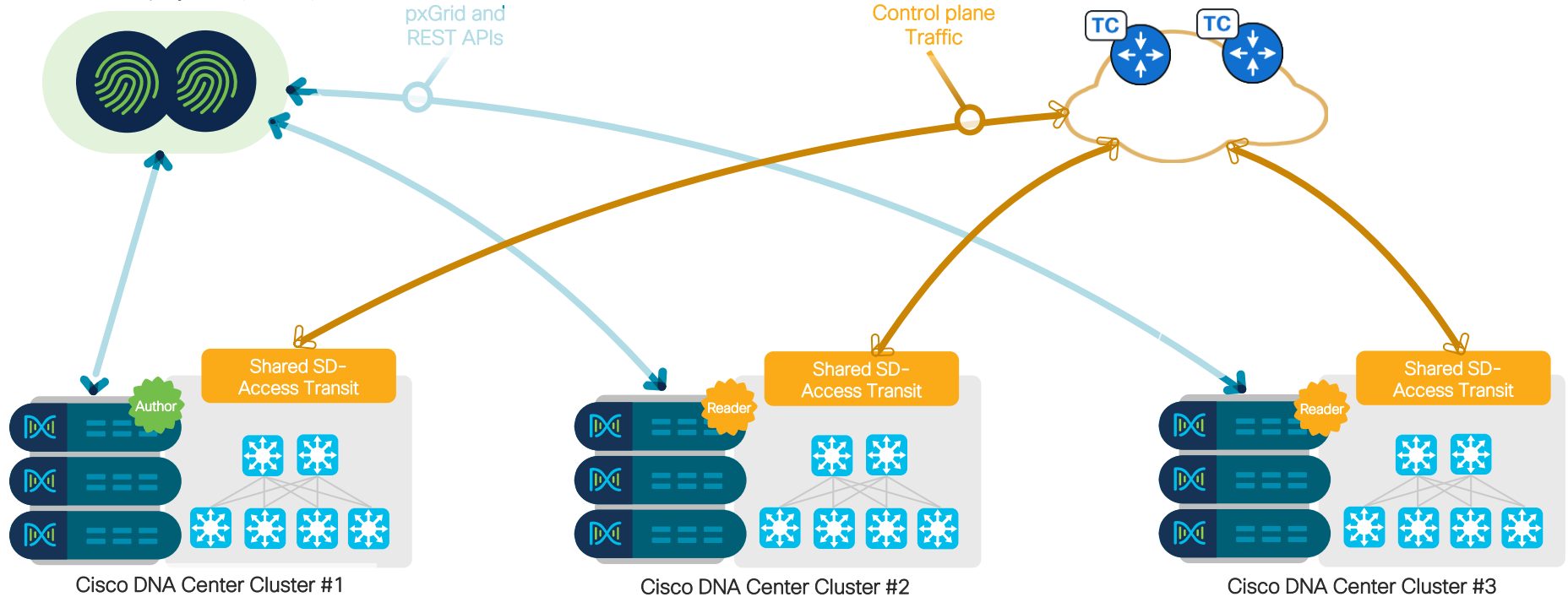

SD-Access Transit shared across multiple Cisco DNA Center Clusters

Multiple Cisco DNA Center

LISP Extranet Policy- Scenario 1(Shared Policy)

With Shared SD-A Transit

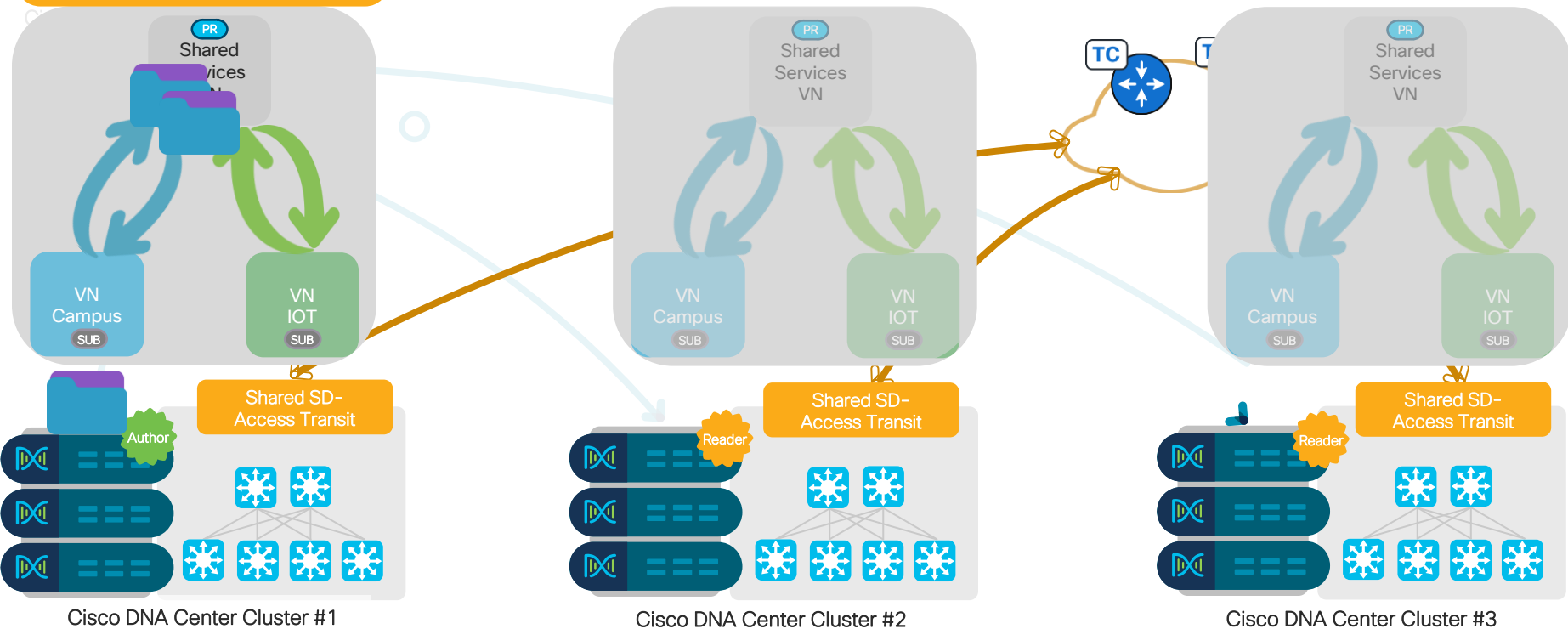

Cisco DNA Center Cluster #1

Cisco DNA Center Cluster #2

Cisco DNA Center Cluster #3

SD-Access Transit shared across multiple Cisco DNA Center Clusters

Cisco DNA Center Policy

Third-Party AAA/RADIUS Server support

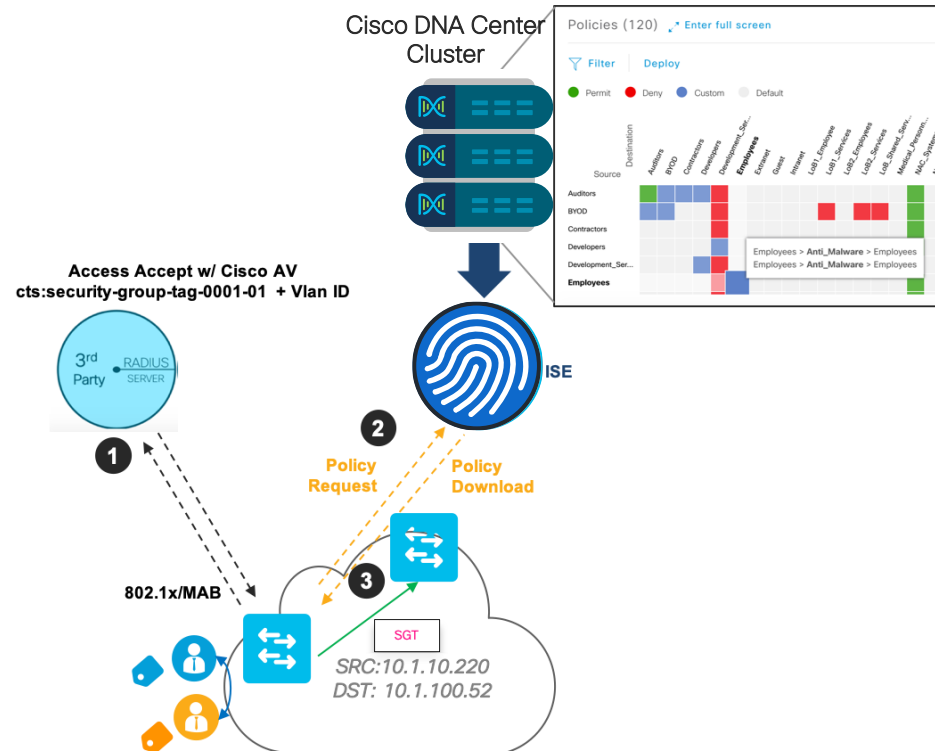
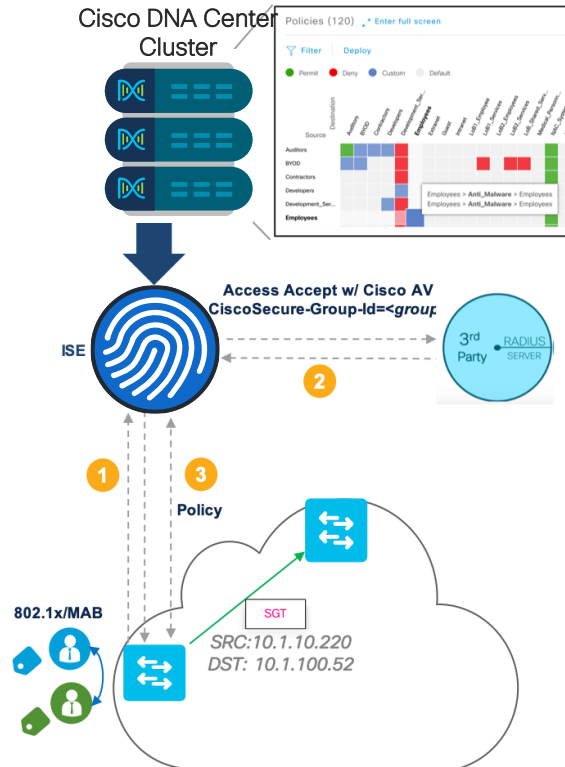

Cisco SD-Access Collaterals



Cisco Software-Defined Access for Industry Verticals



Cisco Software-Defined Access Enabling intent-based networking



Cisco SD-Access YouTube Link

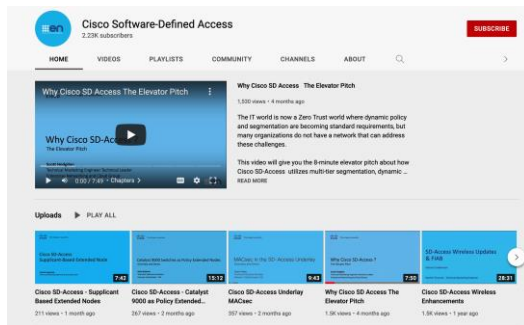

Cisco SD-Access SalesConnect Link

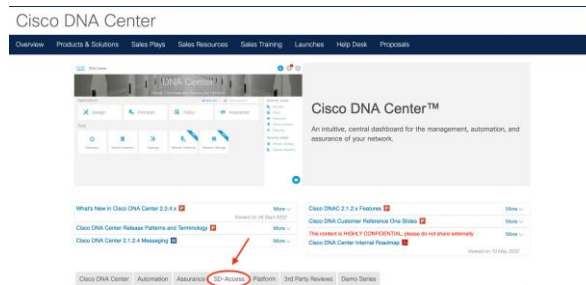

SD-Access BU Engagement Form

SD-Access BU Design Council Form

Multiple Cisco DNA Center LA Form

Cisco SD-Access Design Tool

EN&C Validated Designs



Complete your Session Survey

- Please complete your session survey after each session. Your feedback is important.
- Complete a minimum of 4 session surveys and the Overall Conference survey (open from Thursday) to receive your Cisco Live t-shirt.
- All surveys can be taken in the Cisco Events Mobile App or by logging in to the Session Catalog and clicking the "Attendee Dashboard" at



<https://www.ciscolive.com/emea/learn/sessions/session-catalog.html>

Continue Your Education



Visit the Cisco Showcase for related demos.



Book your one-on-one Meet the Engineer meeting.



Attend any of the related sessions at the DevNet, Capture the Flag, and Walk-in Labs zones.



Visit the On-Demand Library for more sessions at ciscolive.com/on-demand.



The bridge to possible

Thank you

CISCO *Live!*

CISCO *Live!*

ALL IN