



The bridge to possible

Automate Traditional 3-Tier vPC based Deployments using NDFC

Karishma Gupta

Technical Leader, Technical Marketing Engineer

Data Center and Provider Connectivity BU

BRKDCN-1659

CISCO *Live!*

#CiscoLive

Cisco Webex App

Questions?

Use Cisco Webex App to chat with the speaker after the session

How

- 1 Find this session in the Cisco Live Mobile App
- 2 Click “Join the Discussion”
- 3 Install the Webex App or go directly to the Webex space
- 4 Enter messages/questions in the Webex space

Webex spaces will be moderated by the speaker until June 7, 2024.

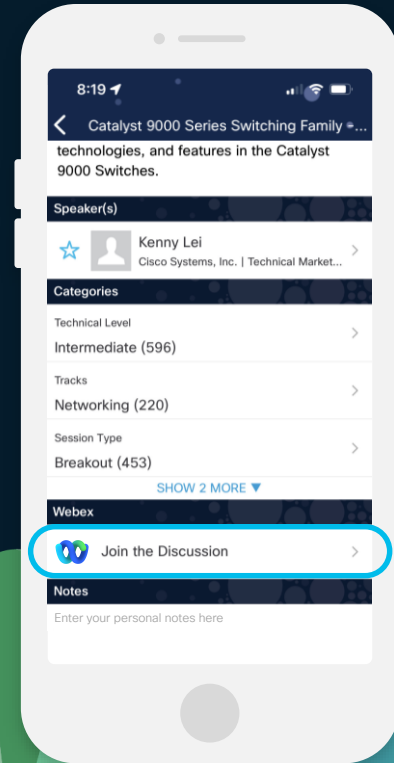



Agenda

- Introduction to NDFC
- Enhanced Classic LAN (ECL)
- Day 0, Day 1, Day 2 with ECL
- Co-existence/Migration from Classic LAN to VXLAN
- Conclusion

Introduction to NDFC

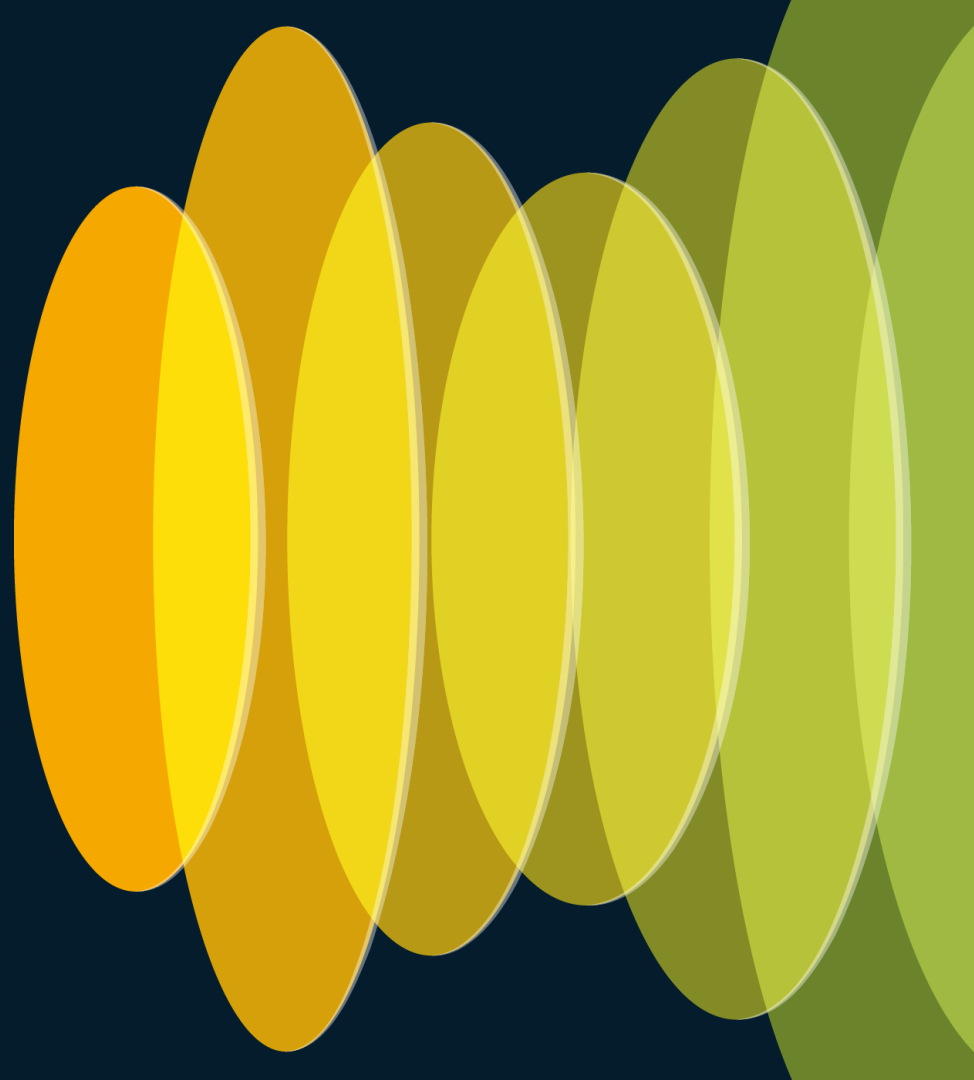

Cisco Nexus Dashboard

Simple to automate, simple to consume

Powering automation
Unified agile platform

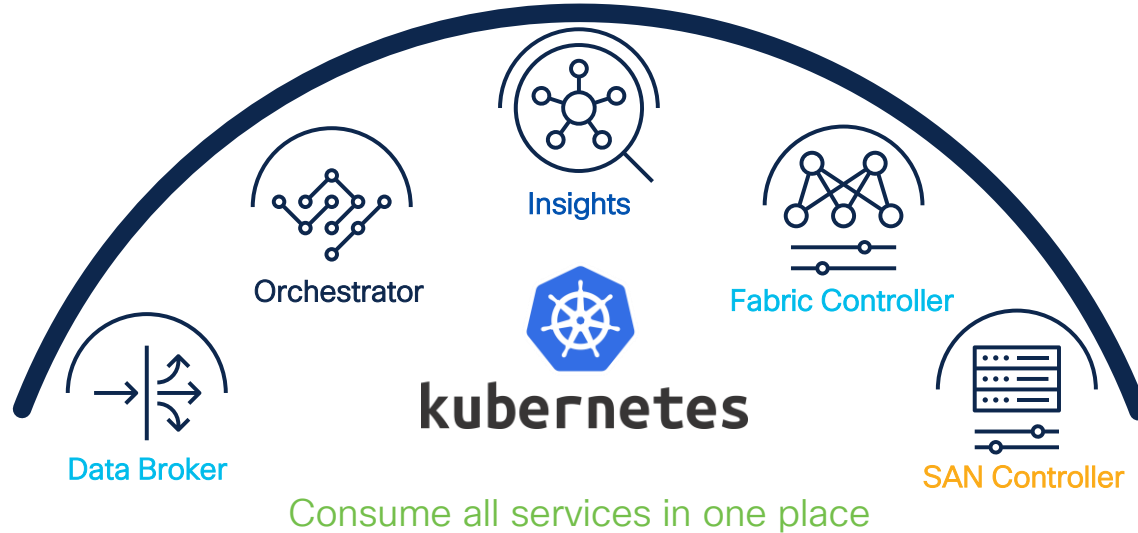

Private cloud

| Third-party Apps

Public cloud



aws



Google Cloud



Azure

Cisco Nexus Dashboard



kubernetes

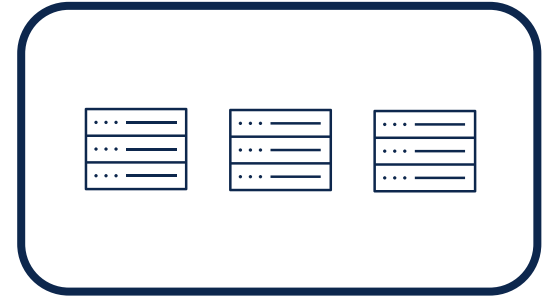

Physical ND Cluster

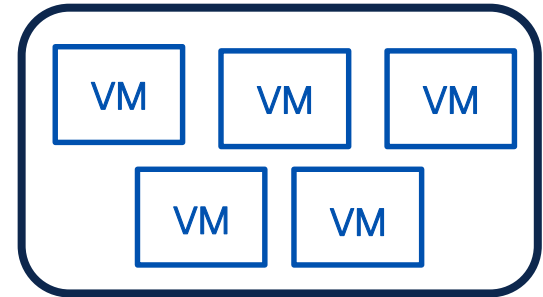

Virtual ND Cluster

Cisco Nexus Dashboard Fabric Controller

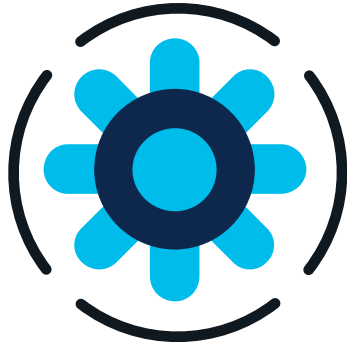

Automation

Accelerate provisioning
and simplify deployments



Management

In depth Management
and control for all
network deployments



Visibility

Get Centralized Visibility
and Monitoring views

Benefits of NDFC 12 over DCNM 11

Plan your migration today!



Simplified Installation from Cisco App Store



Single Experience with a **common Web GUI** which simplifies adoption across the entire **Data Center Networking Product Portfolio**



Easier implementation of various personas namely **LAN**, **SAN**, **IPFM** controller



Easier scalability with adding extra nodes to the cluster dynamically

Feature Manager

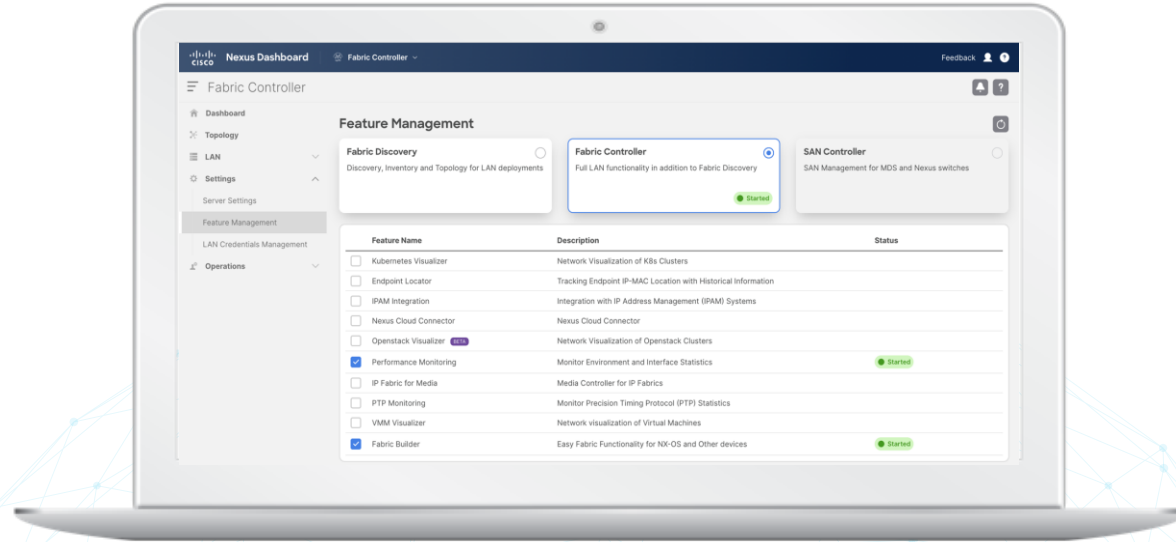

No need for mode selection
at installation time



ND fabric discovery selection
for monitoring capabilities



Selectively enable and disable
features such as fabric discovery,
LAN, IPFM, and SAN and more

Why NDFC?



Multi-Architecture

VXLAN, Multi-Site,
Classic Ethernet, Routed
Fabric



Multi-Topology,
Multi-Protocol

For example – In Legacy
networks, choose from 3 Tier or
Collapsed Core, choose to run
OSPF or BGP



Multi-Domain,
Multi-Platform

LAN,SAN, Media Fabrics
Nexus 2k/5k/6k/7k/9k, MDS, IOS-
XE, IOS-XR, Non-Cisco

Why NDFC?

Multi-Architecture

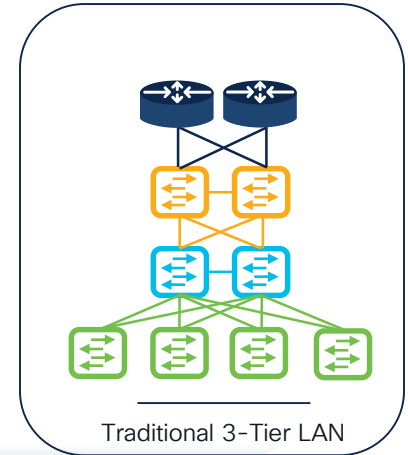
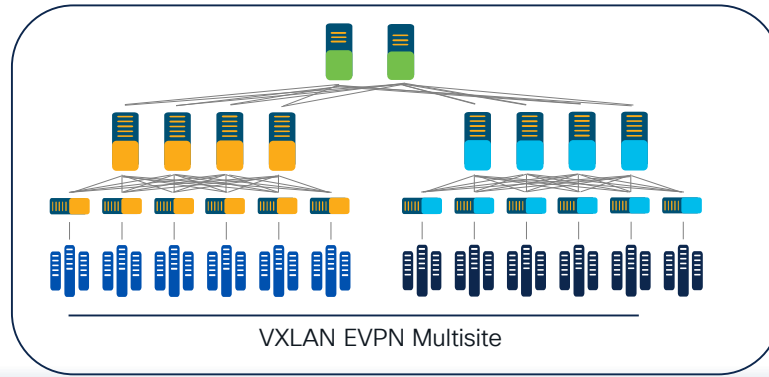
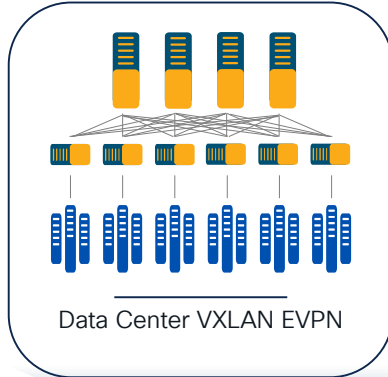
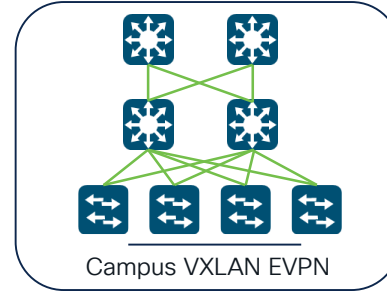
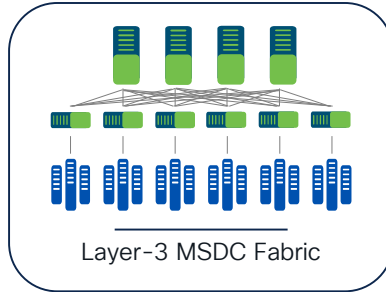

Why NDFC?

Multi-Topology, Multi-Protocol



Rich set of control plane and data plane possibilities available

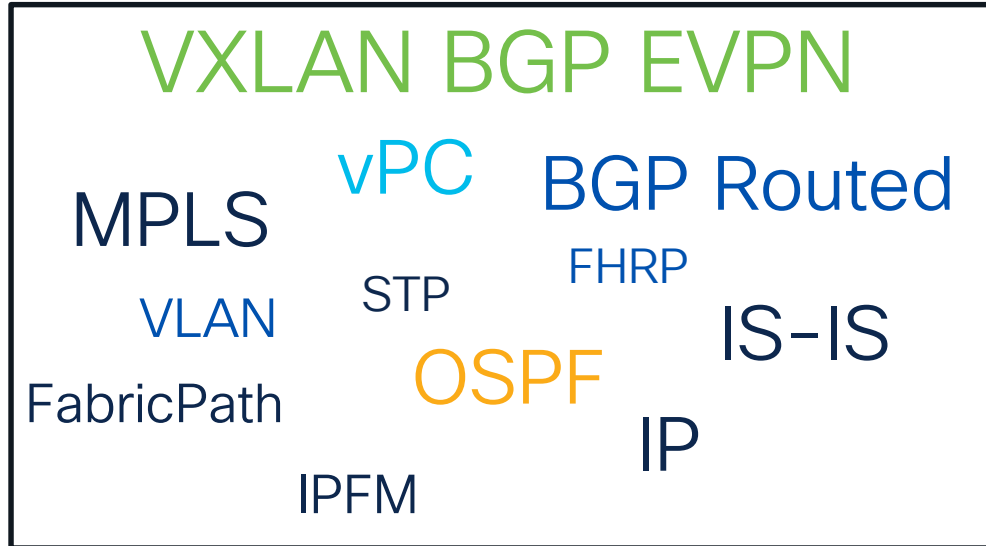

Why NDFC?

Multi-Domain, Multi-Platform



NX-OS Nexus 9000 and 3000



IOS-XE Catalyst 9000



IOS-XR ASR 9000



NX-OS Nexus 7000



IOS-XE ASR 1000



Supported Hardware and Software might vary depending on NDFC version

[Check compatibility matrix](#)

CISCO *Live!*



Enhanced Classic LAN

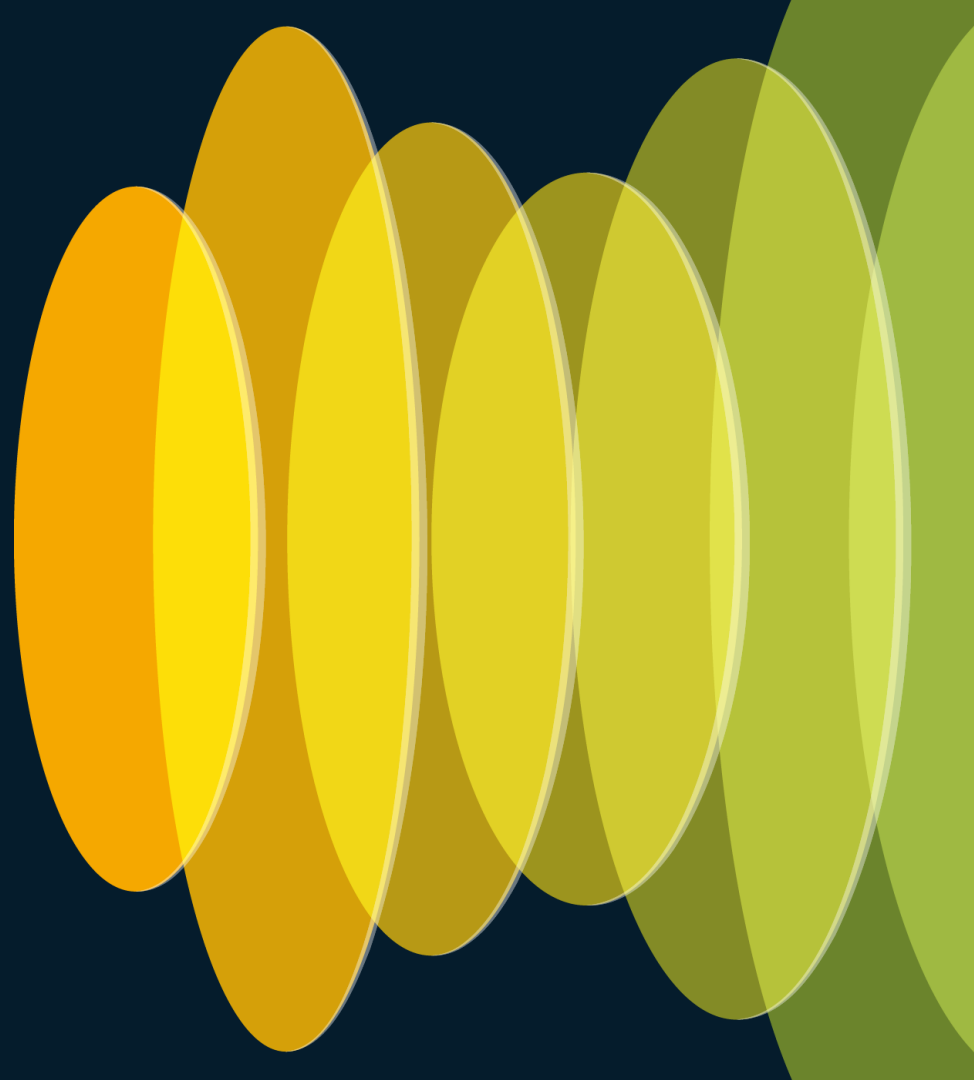

Networks today!

1. Large % still on Legacy Networking
2. No SDN / Automation
3. Most applications don't yet need Overlays
4. Large install base of Nexus (Nexus 7k, Nexus 9k)

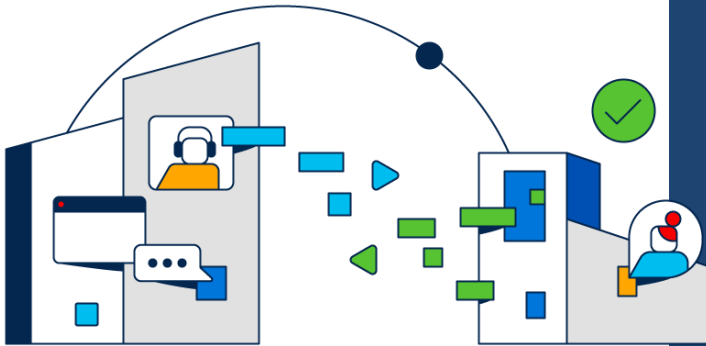

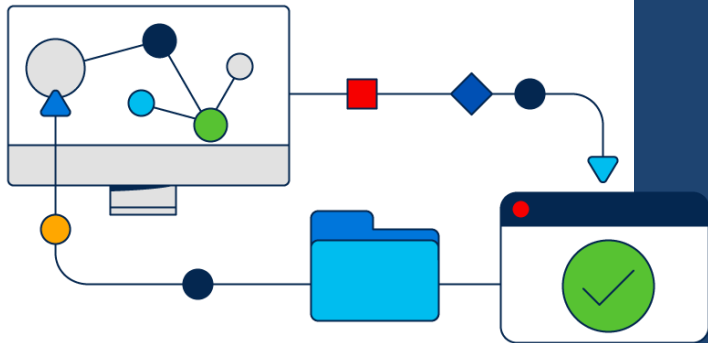

Problem!

1. Switch by switch configuration
2. Use of CLI
3. Manual checks of best practice configurations, config and design guides
4. Manual configurations for Spanning Tree, FHRP, vPCs, allowing VLANs, routing between Agg and Core, VRF-Lite etc.

Solution with Enhanced Classic LAN



Ease of Configurations

Configure at scale

Automate the network

No manual push

Single pane of glass

Intent based Configurations

Role based configs (Access, Agg, Core)

One click vPC pairing

Auto config of b2b vPC between Access and Agg

Config of Networks and VRFs using policies

VRF-Lite config

Modernize your network

Use integrated best practices in NDFC

Preview before you deploy

Use Change Control and Rollback

Get VXLAN ready

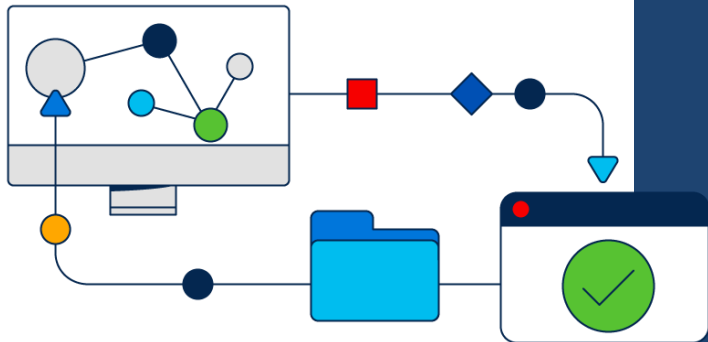

End State!

1. Adoption of SDN
2. Keep the same architecture, but use the latest Nexus 9k hardware
3. Investment protection for Nexus 7000
4. Journey to VXLAN

Fabric Type to be used for Enhanced Classic LAN

Create Fabric and select Enhanced Classic LAN as Fabric Type

The screenshot displays the Cisco Fabric Controller interface. The main view shows a table of existing fabrics. A modal window titled "Select Type of Fabric" is open, showing a search bar and a list of fabric types. The "Enhanced Classic LAN" option is highlighted with a red circle. In the main table, the "Actions" dropdown menu for the "fab-external" fabric is also highlighted with a red circle, showing options for "Create Fabric", "Edit Fabric", and "Delete Fabric".

Fabric Name	Fabric Technology	Fabric Type	ASN	Fabric Status
fab-msd	VXLAN EVPN	VXLAN EVPN Multi-Site	NA	Healthy
fab1	VXLAN EVPN	Data Center VXLAN EVPN	65000	Minor
fab2	VXLAN EVPN	Data Center VXLAN EVPN	65001	Minor
fab-external	Classic LAN	Classic LAN	NA	Major
campus-vxlan	VXLAN EVPN	Campus VXLAN EVPN	32000	Warning

Select Type of Fabric

Search Type of Fabric

- Data Center VXLAN EVPN
Fabric for a VXLAN EVPN deployment with Nexus 9000 and 3000 switches.
- Enhanced Classic LAN**
Fabric for a fully automated 3-tier Classic LAN deployment with Nexus 9000 and 7000 switches.
- Campus VXLAN EVPN
Fabric for a VXLAN EVPN Campus deployment with Catalyst 9000 switches and Nexus 9000 switches.
- BGP Fabric
Fabric for an eBGP based deployment with Nexus 9000 and 3000 switches. Optionally VXLAN EVPN can be enabled on top of the eBGP underlay.
- Custom Network
Fabric for flexible deployments with a mix of Nexus and Non-Nexus devices.
- Fabric Group
Domain that can contain Enhanced Classic LAN, Classic LAN, and External Connectivity Network fabrics.

Select

With Enhanced Classic LAN – Full support for Brownfield with Configuration Compliance



Enhanced Classic LAN will allow users to import existing switches into a fabric



‘preserve config = yes’ and incrementally manage switches from NDFC, while preserving existing configs

Traditional 3-Tier Classic Ethernet Networks

Deployment considerations

Option-1:
3-Tier with Agg as L2/L3 boundary

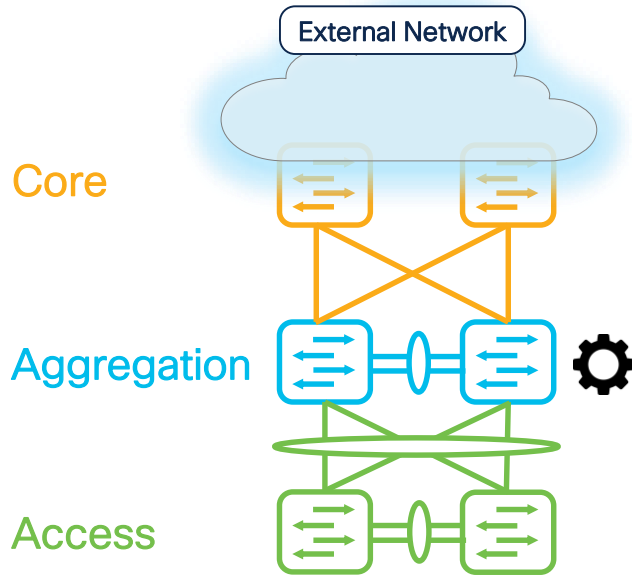

Option-2:
2-Tier with Collapsed Core as L2/L3 boundary

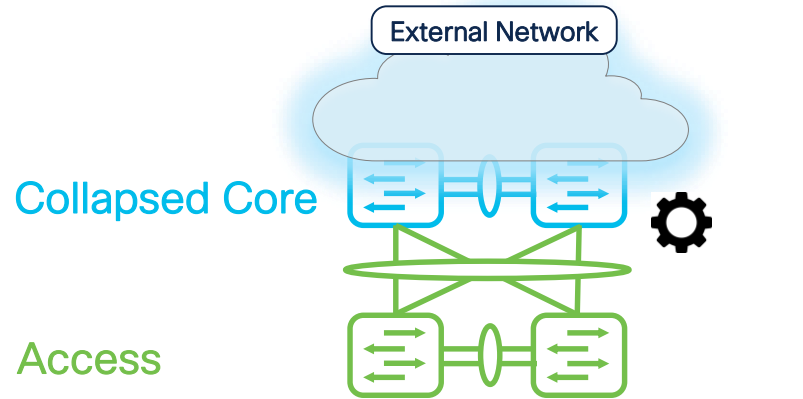

 Layer-2/Layer-3 boundary

Guidelines and Limitations

For Reference

1

Supported platform in ECL fabric: Nexus 9000, Nexus 7000, Nexus 3000 and Nexus 2000 (FEX)

2

Greenfield and Brownfield supported

3

Nexus 9000 is recommended at Access and Aggregation layer

4

Nexus 9000 or Nexus 7000 is recommended at Core layer. Non-Nexus also supported

5

VPC domain is mandatory at Aggregation / Collapsed Core

6

Multiple Aggregation pairs supported in same fabric with no overlapping VLANs only for Greenfield











7

No support for Inband Management and Inband POAP for devices in ECL fabric

8

Auto VRF-Lite supported from Aggregation to Core/Edge roles when these are Nexus switches

What's new in NDFC for Classic LAN?

FEATURES	CLASSIC LAN (DCNM 11 and later)	ENHANCED CLASSIC LAN (NDFC 12.1.3 and later)
Inventory, Discovery, Topology visualization		
Nexus Platforms supported	Nexus 9k/7k/6k/5k/2k	Nexus 9k/N7k/3k/2k
True support for Greenfield and Brownfield		
Auto Provisioning of 3 Tier network		
Networks and VRF provisioning		
Auto deployment of VRF Lite with Core		

Enhanced Classic LAN Day-0

Enhanced Classic LAN Greenfield

Not on Enhanced Classic LAN Today?



Step 2

Discover

Import switches with POAP or Day-0 config
Define switch Roles (Access or Aggregation)
Create vPC pairs



Step 1

Create

Define fabric settings (FHRP, Routing, VLAN) -
STP, VPC pairing, VLAN pool, etc.



Step 3

Recalculate and Deploy

Generates config based on intent
Preview side by side diffs

Cisco best practice implemented

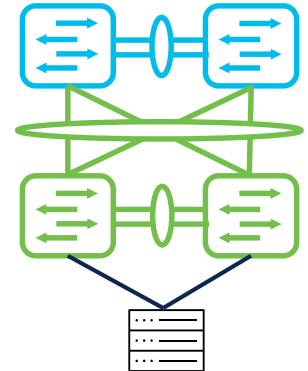

Fast, automated process



Step 1 -> Create a Fabric

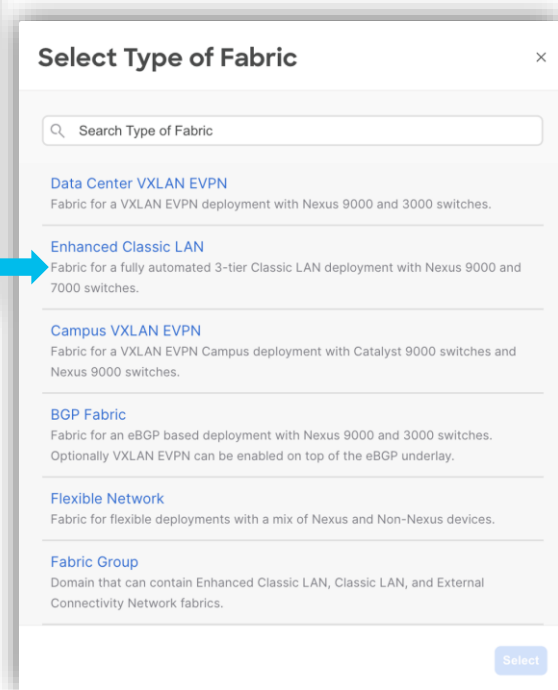
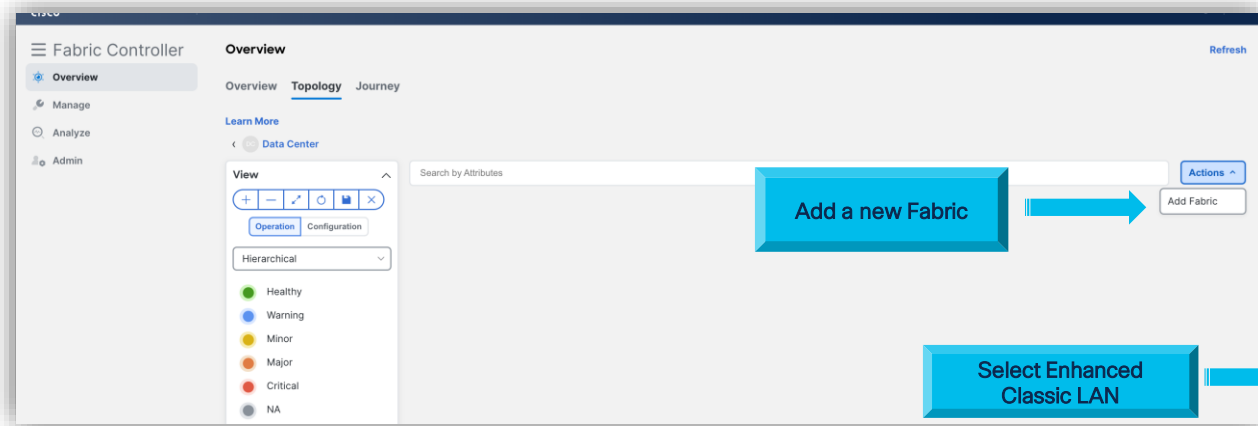

Provide Fabric Name

Fabric Name
Classic-LAN

Pick a Template

Pick a Fabric

Choose Fabric

Step 1 -> Create a Fabric

(continued)

Create Fabric

Fabric Name
Classic-LAN

Pick Fabric
[Enhanced Classic LAN >](#)

General Parameters | Spanning Tree | vPC | Protocols | Advanced | Resources | Manageability | Bootstrap | Configuration Backup | Flow Monitor

First Hop Redundancy Protocol
hsrp | HSRP or VRRP

Routing Protocol
ebgp | VRF Lite Aggregation-Core or Collapsed Core-WAN Peering Protocol Options

BGP ASN*
65535 | 1-4294967295 | 1-65535[0-65535] It is a good practice to have a unique ASN for each Fabric

Enable Performance Monitoring | **PM Metrics**

FHRP - HSRP,
VRRP, None

Routing Protocol -
eBGP, OSPF, None

BGP ASN

PM Metrics

Step 1 -> Create a Fabric

(continued)

Spanning Tree Protocol - RPVST, MST, Unmanaged

VLAN range

STP Bridge Priority

Fabric Name
Classic-LAN

Pick Fabric
Enhanced Classic LAN >

General Parameters **Spanning Tree** VPC Protocols Advanced Resources Manageability Bootstrap Configuration Backup Flow Monitor

Spanning Tree Root Bridge Protocol
rpvst+
Protocol to be used for configuring Root Bridge: rpvst+: Rapid Per-VLAN Spanning Tree, mst: Multiple Spanning Tree, unmanaged (default): STP Root not managed by NDFC. Note: Spanning Tree Settings and Bridge Configs are applicable at Aggregation layer only

Spanning Tree VLAN Range*
1-3967
Vlan range, Example: 1,3-5,7,9-11, Default is 1-3967 (Applicable only for Aggregation devices)

MST Instance Range
MST instance range, Example: 0-3,5,7-9, Default is 0 (Applicable only for Aggregation devices)

Spanning Tree Bridge Priority
0
Bridge priority for the spanning tree in increments of 4096 (Applicable only for Aggregation devices)

Spanning Tree Hello Interval
2
Set the number of seconds between generation of config bpdu, default is 2 (Applicable only for Aggregation devices)

Spanning Tree Forward Delay
15
Set the number of seconds for the forward delay timer, default is 15 (Applicable only for Aggregation devices)

Spanning Tree Max Age Interval
20
Set the maximum number of seconds the information in a bpdu is valid, default is 20 (Applicable only for Aggregation devices)

Spanning Tree Pathcost Method
short
long: Use 32 bit based values, short (default): Use 16 bit based values for default port path costs (Applicable only for Aggregation devices)

Step 1 -> Create a Fabric

(continued)

Fabric Name
Classic-LAN

Pick Fabric
[Enhanced Classic LAN >](#)

General Parameters **vPC** Spanning Tree Protocols Advanced Resources Manageability Bootstrap Configuration Backup Flow Monitor

vPC Auto Recovery Time (In Seconds)
360 (Min:240, Max:3600)

vPC Delay Restore Time (In Seconds)
150 (Min:1, Max:3600)

vPC Peer Link Port Channel ID
500 (Min:1, Max:4096)

vPC IPv6 ND Synchronize Enable IPv6 ND synchronization between vPC peers

vPC Domain Id Range
1-1000 vPC Domain Id range to use for new pairings

vPC Layer-3 Peer-Router Option Enable Layer-3 Peer-Router on all Aggregation Devices

Allow Selective VLANs on vPC Peer-link Allow VLANs associated with VRFs/Networks to be trunked on the vPC Peer-Link between Aggregation Devices

Cisco's Best Practice VPC parameters

Step 1 -> Create a Fabric (continued)

General Parameters Spanning Tree vPC Protocols Advanced **Resources** Manageability Bootstrap Configuration Backup Flow Monitor

Network VLAN Range
2300-2999 Per Switch Network VLAN Range (Min:2, Max:4094)

Aggregation-Core/Aggregation-Edge Connectivity
Auto VRF Lite Aggregation-Core and Aggregation-Edge Router Inter-Fabric Connection Options

VRF Lite Subinterface dot1q Range
2-511 Per Aggregation dot1q Range for VRF Lite Connectivity (Min:2, Max:4093)

Auto Generate VRF Lite Configuration on Aggregation and Core/Edge
 Flag that controls auto generation of VRF Lite sub-interface and peering configuration on Aggregation & Core/Edge devices. If set, auto created VRF Lite links will have 'Auto Generate Flag' enabled

VRF Lite IP Version*
IPv4_only Choice of IPv4, IPv6 or both

IPv4 VRF Subnet IP Range*
10.33.0.0/16 IPv4 address range to assign P2P Aggregation-Core connections, and peering between vPC Aggregation switches

IPv4 VRF Lite Subnet Mask Length*
30

Network VLAN Range

Auto Generate VRF-Lite Config when Core/Edge is Nexus

VRF-Lite IP Version - v4, v6 or both

Step 2 -> Add Switches

The screenshot displays a network management interface with the following elements:

- Overview** header with a **Refresh** button in the top right.
- Navigation tabs: **Overview**, **Topology** (selected), and **Journey**.
- Breadcrumbs: **Data Center** > **Classic-LAN**.
- Left sidebar with a **View** panel containing:
 - Navigation icons: +, -, zoom, refresh, save, close.
 - Toggle: **Show Logical Links** (disabled).
 - Buttons: **Operation**, **Configuration** (selected).
 - Dropdown: **Hierarchical**.
 - Status Legend:
 - In-Sync (green circle)
 - Pending (blue circle)
 - In Progress (yellow circle)
 - Out-of-Sync (red circle)
 - NA (grey circle)
 - Multi-select: **Multi-select** (disabled), **0 selected**.
- Filter: **Filter by Attributes**.
- Right sidebar with an **Actions** dropdown menu (highlighted with a blue box) containing:
 - Detailed View
 - Edit Fabric
 - Add Switches** (highlighted with a blue box)
 - Recalculate and Deploy
 - More >
- Central callout: A blue box with the text **Add switches inside the fabric** and a blue arrow pointing to the **Add Switches** menu item.

Step 2 -> Add Switches (continued)

- NDFC uses SSH, SNMP, and CDP to discover seed and switches 'x' hop away from seed
- Seed IP must be management IP of switch

Switch Addition Mechanism*

Discover

Seed Switch Details

Seed IP*
192.18.0.13-17

i Ex: "2.2.2.20" or "10.10.10.40-60" or "2.2.2.20, 2.2.2.21"

Authentication Protocol*
MDS

Username*
admin

Password*
.....

Set as individual device write credential

Max Hops*
0

Preserve Config

i Unchecking this will clean up the configuration on switch(es)

Step 2 -> Add Switches (continued)

Add Switches - Fabric: Classic-LAN

Switch Addition Mechanism*
 Discover

Seed Switch Details

Fabric	Switch	Authentication Protocol	Username
Classic-LAN	192.18.0.13-17	MD5	admin
Password	Max Hops	Preserve config	
<input type="checkbox"/> Set as individual device write credential	0	<input checked="" type="radio"/> Disabled	

[← Back](#)

Discovery Results

Filter by attributes

<input checked="" type="checkbox"/>	Switch Name	Serial Number	IP Address	Model	Version	Status	Progress
<input checked="" type="checkbox"/>	Agg1	9EEM1T58D89	192.18.0.16	N9K-C9300v	9.3(9)	Manageable	
<input type="checkbox"/>	Access3	95HAQMOPOM8	192.18.0.15	N9K-C9300v	9.3(9)	Already Managed in Classic-LAN-Fabric2	
<input checked="" type="checkbox"/>	Access1	9HMPQNTXEV	192.18.0.13	N9K-C9300v	9.3(9)	Manageable	
<input checked="" type="checkbox"/>	Access2	9MZSTD2N4ML	192.18.0.14	N9K-C9300v	9.3(9)	Manageable	
<input checked="" type="checkbox"/>	Agg2	9UEXH9V6Z9L	192.18.0.17	N9K-C9300v	9.3(9)	Manageable	

5 items found

Rows per page 10 < 1 >

Switch Inventory
Management

Step 2 -> Add Switches (continued)

Discovery Results

Filter by attributes

<input type="checkbox"/>	Switch Name	Serial Number	IP Address	Model	Version	Status	Progress
<input type="checkbox"/>	Agg1	9EEM1T58D89	192.18.0.16	N9K-C9300v	9.3(9)	Switch Added	<div style="width: 100%; height: 10px; background-color: green;"></div>
<input type="checkbox"/>	Access3	95HAQMOPOM8	192.18.0.15	N9K-C9300v	9.3(9)	Already Managed in Class-LAN-Fabric2	
<input type="checkbox"/>	Access1	9HMPQ6NTXEV	192.18.0.13	N9K-C9300v	9.3(9)	Switch Added	<div style="width: 100%; height: 10px; background-color: green;"></div>
<input type="checkbox"/>	Access2	9MZSTD2N4ML	192.18.0.14	N9K-C9300v	9.3(9)	Switch Added	<div style="width: 100%; height: 10px; background-color: green;"></div>
<input type="checkbox"/>	Agg2	9UEXH9V6Z9L	192.18.0.17	N9K-C9300v	9.3(9)	Switch Added	<div style="width: 100%; height: 10px; background-color: green;"></div>

Switch successfully
added into NDFC

Step 3 -> Set Role

The screenshot displays a network management interface. At the top, there are tabs for 'Overview', 'Topology', and 'Journey', with 'Topology' selected. Below the tabs, there is a breadcrumb path: 'Data Center > Classic-LAN'. A 'View' sidebar is open on the left, containing a toolbar with zoom and pan icons, a 'Show Logical Links' toggle, and two buttons: 'Operation' and 'Configuration'. A dropdown menu is open, showing 'Hierarchical' selected, with other options like 'Healthy', 'Warning', 'Minor', 'Major', 'Critical', and 'NA'. Below the sidebar, a topology diagram shows four nodes: 'Access1', 'Access2', 'Agg1', and 'Agg2', connected in a line. A 'Select Role' dialog is open on the right, with a search bar and two options: 'Access (current)' and 'Aggregation'.

Step 4 -> VPC Pairing

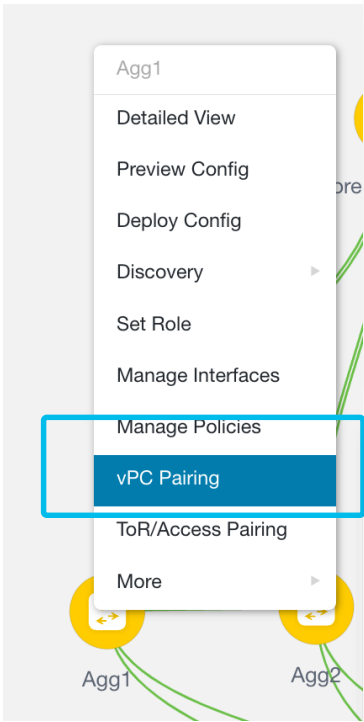

vPC Pairing

Select vPC Peer for Agg1

Filter by attributes

Device	Recommended	Reason	Serial Number
<input checked="" type="radio"/> Agg2	True	Switches are connected and have same role	9UEXH9V6Z9L
<input type="radio"/> Access2	False	Switches have different roles	9MZSTD2N4ML
<input type="radio"/> Access1	False	Switches have different roles	9HMPQ6NTXEV

vPC Pairing

Select vPC Peer for Access1

Filter by attributes

Device	Recommended	Reason	Serial Number
<input checked="" type="radio"/> Access2	True	Switches are connected and have same role	9MZSTD2N4ML
<input type="radio"/> Agg2	False	Already paired with 9EEM1T58D89 (Agg1)	9UEXH9V6Z9L
<input type="radio"/> Agg1	False	Already paired with 9UEXH9V6Z9L (Agg2)	9EEM1T58D89

Step 5 -> Recalculate and Deploy

The screenshot displays a network management interface with the following components:

- Overview:** Includes tabs for Overview, Topology (selected), and Journey. A 'Refresh' button is in the top right.
- Navigation:** 'Learn More' link and breadcrumb 'Data Center > Classic-LAN'.
- View Panel (Left):** Contains zoom controls (+, -, pan, reset, close), a 'Show Logical Links' toggle, 'Operation' and 'Configuration' tabs, a 'Hierarchical' view dropdown, a status legend (Healthy, Warning, Minor, Major, Critical, NA), and a 'Multi-select' toggle.
- Search:** A 'Search by Attributes' input field.
- Topology Diagram:** A hierarchical network diagram with a 'Core-Backbone' node at the top, two 'Agg' nodes (Agg1, Agg2) in the middle, and four 'Access' nodes (Access1, Access2) at the bottom. Green lines represent connections.
- Actions Menu (Right):** A dropdown menu with options: 'Detailed View', 'Edit Fabric', 'Add Switches', 'Recalculate and Deploy' (highlighted with a blue box), and 'more'. The 'Actions' button that opens this menu is also highlighted with a blue box.

Step 5 -> Recalculate and Deploy

(continued)

Deploy Configuration - Classic-LAN

1 Config Preview 2 Deploy Progress

Filter by attributes Resync All

Switch Name	IP Address	Role	Serial Number	Fabric Status	Pending Config	Status Description	Progress	Resync Switch
Agg1	192.18.0.16			Out-Of-Sync	423 Lines	Out-of-Sync	<div style="width: 100%; height: 10px; background-color: green;"></div>	Resync
Access1	192.18.0.13	access	9HMPQ6NTXEV	Out-Of-Sync	465 Lines	Out-of-Sync	<div style="width: 100%; height: 10px; background-color: green;"></div>	Resync
Agg2	192.18.0.17	aggregation	9UEXH9V6Z9L	Out-Of-Sync	423 Lines	Out-of-Sync	<div style="width: 100%; height: 10px; background-color: green;"></div>	Resync
Access2	192.18.0.14	access	9MZSTD2N4ML	Out-Of-Sync	465 Lines	Out-of-Sync	<div style="width: 100%; height: 10px; background-color: green;"></div>	Resync

Fabric Configuration status →

← **Pending Configuration**

Step 5 -> Recalculate and Deploy (continued)

Pending Config - Classic-LAN - Agg1

Pending Config Side-by-Side Comparison

```
cfs eth distribute
feature bgp
feature dhcp
feature hsrp
feature interface-vlan
feature lacp
feature nxapi
feature vpc
nxapi http port 80
nxapi https port 443
router bgp 65535
configure terminal
service dhcp
snmp-server host 192.18.0.10 traps version 2c public udp-port 2162
ip dhcp relay
route-map FABRIC-RMAP-REDIST-SUBNET permit 10
  match tag 12345
ip dhcp relay information option
ip dhcp relay information option vpn
ipv6 dhcp relay
vpc domain 1
  ip arp synchronize
  peer-gateway
  peer-switch
  delay restore 150
  peer-keepalive destination 192.18.0.17 source 192.18.0.16
  auto-recovery reload-delay 360
  ipv6 nd synchronize
```

Aggregation
role related
features

```
vpc domain 1
  ip arp synchronize
  peer-gateway
  peer-switch
  delay restore 150
  peer-keepalive destination 192.18.0.17 source 192.18.0.16
  auto-recovery reload-delay 360
  ipv6 nd synchronize
interface port-channel500
  switchport
  switchport mode trunk
  spanning-tree port type network
  description "vpc-peer-link Agg1--Agg2"
  no shutdown
  vpc peer-link
interface ethernet1/1
  channel-group 500 force mode active
  description "P0 500 (vpc-peer-link) member Agg1-Ethernet1/1 to Agg2-Ethernet1/1"
  no shutdown
interface port-channel1
  switchport
  switchport mode trunk
  mtu 9216
  vpc 1
  spanning-tree bpduguard disable
  spanning-tree guard root
  description vPC-aggregation-connected-to-vPC-access:Access1--Access2-vPC1
  no shutdown
```

VPC domain
towards Agg02

VPC peer-link
towards Agg02

Step 5 -> Recalculate and Deploy (continued)

Pending Config - Classic-LAN - Agg1

Pending Config Side-by-Side Comparison

```
interface port-channel1
switchport
switchport mode trunk
mtu 9216
vpc 1
spanning-tree bpduguard disable
spanning-tree guard root
description vPC-aggregation-connected-to-vPC-access:Access1~Access2~vPC1
no shutdown
switchport trunk allowed vlan none
```

VPC PO towards
Access01-02 switches

Pending Config - Classic-LAN - Agg1

Pending Config Side-by-Side Comparison

```
no shutdown
switchport trunk allowed vlan none
interface ethernet1/64
switchport
switchport mode trunk
mtu 9216
no shutdown
switchport trunk allowed vlan none
interface ethernet1/7
switchport
switchport mode trunk
mtu 9216
no shutdown
switchport trunk allowed vlan none
interface ethernet1/8
switchport
switchport mode trunk
mtu 9216
no shutdown
switchport trunk allowed vlan none
interface ethernet1/9
switchport
switchport mode trunk
mtu 9216
no shutdown
switchport trunk allowed vlan none
spanning-tree vlan 1-3967 priority 0
```

Aggregation default
port-type

STP Root on
Aggregation

Step 5 -> Recalculate and Deploy (continued)

Pending Config - Classic-LAN - Access1

Pending Config Side-by-Side Comparison

```
cfs eth distribute
feature lacp
feature lldp
feature vpc
snmp-server host 192.18.0.10 traps version 2c public udp-port 2162
vpc domain 2
  peer-keepalive destination 192.18.0.14 source 192.18.0.13 hold-ti
  peer-switch
  auto-recovery reload-delay 360
interface port-channel500
  switchport
  switchport mode trunk
  description "vpc-peer-link Access1--Access2"
  no shutdown
  spanning-tree port type network
  switchport trunk allowed vlan 1-4094
  vpc peer-link
interface ethernet1/1
  description "PO 500 (vpc-peer-link) member Access1-Ethernet1/1 to Access2-Ethernet1/1"
  channel-group 500 force mode active
  no shutdown
```

Access role
related features

VPC domain
towards
Access02

VPC peer-link
towards Access02

Pending Config - Classic-LAN - Access1

Pending Config Side-by-Side Comparison

```
...
interface port-channel1
  switchport
  switchport mode trunk
  description vPC-access-connected-to-vPC-aggregation:Agg2-Agg1-vPC1
  mtu 9216
  vpc 1
  spanning-tree bpduguard disable
  spanning-tree guard loop
  no shutdown
  switchport trunk allowed vlan none
interface ethernet1/10
  switchport
  switchport mode trunk
  mtu 9216
  spanning-tree port type edge trunk
  no shutdown
  switchport trunk allowed vlan none
interface ethernet1/11
  switchport
  switchport mode trunk
  mtu 9216
  spanning-tree port type edge trunk
  no shutdown
  switchport trunk allowed vlan none
interface ethernet1/12
  switchport
  switchport mode trunk
  mtu 9216
```

VPC PO towards Agg01-
02 switches

Access default
port-type

NDFC Enhanced Classic LAN Topology View

The screenshot shows the 'Fabric Controller' interface. The 'Overview' tab is active, and the 'Topology' sub-tab is selected. A blue callout box labeled 'Fabric Operational View' points to the top navigation area. On the left, a 'View' sidebar contains a 'Fabric Alarms' callout box pointing to the alarm legend, which includes categories like Healthy, Warning, Minor, Major, Critical, and NA. The main topology diagram shows a 'Core-Backbone' cloud icon connected to two aggregation nodes (Agg1, Agg2), which are in turn connected to two access nodes (Access1, Access2).

The screenshot shows the 'Fabric Controller' interface with the 'Topology' sub-tab selected. A blue callout box labeled 'Link Status' points to the 'View' sidebar, which has a 'Configuration' button selected. Another blue callout box labeled 'Fabric Configuration View' points to the 'Configuration' button. A third blue callout box labeled 'Fabric Configuration Status' points to the status legend, which includes categories like In-Sync, Pending, In Progress, Out-of-Sync, and NA. The main topology diagram is identical to the first screenshot. A 'VPC ID:1' table is overlaid on the bottom right of the topology.

VPC ID:1	
Agg1	Access2
Port-channel1	Port-channel1
Ethernet1/5	Ethernet1/5
Agg1	Access1
Port-channel1	Port-channel1
Ethernet1/4	Ethernet1/4

Enhanced Classic LAN Day-1

Step1 -> Create Network and VRF

The image shows a screenshot of the Cisco DNA Center interface, divided into two main sections. The left section shows the navigation pane with 'Data Center / Classic-LAN / Networks (0)' selected. The 'Actions' menu is open, showing 'Create Network', 'Import Networks', and 'Export Networks'. A blue callout box labeled 'Create Network' points to the 'Create Network' action, and another blue callout box labeled 'CSV Option' points to the 'Import Networks' action. The right section shows the configuration form for a new network. The 'Network Name*' field contains 'MyNetwork_30002', with a blue callout box labeled 'Auto Generated Name' pointing to it. The 'Layer 2 Only' checkbox is unchecked, with a blue callout box labeled 'L2 or L3 Network' pointing to it. The 'VRF Name*' field contains 'MyVRF_50002', with a blue callout box labeled 'VRF' pointing to it. The 'VLAN ID*' field contains '2302', with a blue callout box labeled 'Auto Generated VLAN ID' pointing to it. The 'Network Template*' is set to 'Network_Classic'. The 'General Parameters' tab is active, showing 'IPv4 Gateway/NetMask' as '192.168.1.253/24', with a blue callout box labeled 'Default Gateway SVI' pointing to it. The 'Interface IPv4 addr on active*' field contains '192.168.1.252', and the 'Interface IPv4 addr on standby*' field contains '192.168.1.254', both with blue callout boxes labeled 'FHRP Active/Backup' pointing to them. A small note at the bottom right of the form says 'Example 192.0.2.3: Interface IP address on the standby/back up device'.

Step2 -> Attach Network and VRF

The screenshot displays the Cisco DNA Center interface for network configuration. The main area shows a topology with four nodes: two aggregation switches (Agg1 and Agg2) at the top and two access switches (Access1 and Access2) at the bottom. Agg1 and Agg2 are connected to each other and to both Access1 and Access2. A blue callout box labeled "Select Switches" points to the Agg1 and Agg2 nodes. On the right, an "Actions" menu is open, with "Edit Attachment" highlighted. A blue callout box labeled "Attach Network to Switches" points to the "Edit Attachment" option. The left sidebar contains navigation and view controls, including a breadcrumb trail: "Data Center > Classic-LAN > Networks (1) > MyNetwork_30002". The "View" section shows "Configuration" selected, and a "Multi-select" toggle is turned on, indicating "2 selected".

Overview Refresh

Overview Topology Journey

Learn More

Data Center > Classic-LAN > Networks (1) > MyNetwork_30002

View

Search by Attributes

Actions ^

- Quick Attach
- Quick Detach
- Import Attachments
- Export Attachments
- Edit Attachment**
- History
- Preview
- Deploy

Select Switches

Attach Network to Switches

Agg1 Agg2

Access1 Access2

Multi-select 2 selected

Step2 -> Attach Network and VRF (continued)

Agg1 (9EEM1T58D89) - Agg2 (9UEXH9V6Z9L)

Detach Attach

VLAN ID*
2302

FHRP Active
 Agg1 (9EEM1T58D89)
 Agg2 (9UEXH9V6Z9L)

Available Interfaces for this device Modify Interfaces

Filter by attributes

Interface/Ports	Switch	Status	Port Type	Port Description	Neighbor Info	Policy Name
<input checked="" type="checkbox"/> Ethernet1/10	Access1	false	trunk			int_trunk_host
<input checked="" type="checkbox"/> Ethernet1/10	Access2	false	trunk			int_trunk_host
<input type="checkbox"/> Ethernet1/10	Agg1	false	trunk			int_trunk_host
<input type="checkbox"/> Ethernet1/10	Agg2	false	trunk			int_trunk_host
<input type="checkbox"/> Ethernet1/11	Access1	false	trunk			int_trunk_host
<input type="checkbox"/> Ethernet1/11	Access2	false	trunk			int_trunk_host
<input type="checkbox"/> Ethernet1/11	Agg1	false	trunk			int_trunk_host
<input type="checkbox"/> Ethernet1/11	Agg2	false	trunk			int_trunk_host
<input type="checkbox"/> Ethernet1/12	Access1	false	trunk			int_trunk_host
<input type="checkbox"/> Ethernet1/12	Access2	false	trunk			int_trunk_host

Port Attachment

Network Auto Attached to Agg

VLAN ID

Select FHRP Active per Network

Switches

Cancel Save

Network and VRF Configs

Pending Config - Classic-LAN - Agg1

Pending Config Side-by-Side Comparison

```
vrf context MyVRF_50002
  address-family ipv4 unicast
  address-family ipv6 unicast
exit
interface Vlan2000
  vrf member MyVRF_50002
  ip address 10.33.0.1/30
  ipv6 address 2001::10:33:0:1/126
  mtu 9216
  no ip redirects
  no ipv6 redirects
  no shutdown
exit
router bgp 65535
  vrf MyVRF_50002
    address-family ipv4 unicast
      redistribute direct route-map FABRIC-RMAP-REDIST-SUBNET
    exit
    address-family ipv6 unicast
      redistribute direct route-map FABRIC-RMAP-REDIST-SUBNET
    exit
  neighbor 10.33.0.2
  remote-as 65535
  address-family ipv4 unicast
    send-community both
  exit
  neighbor 2001::10:33:0:2
```

VRF, SVI and
BGP Configs

```
vlan 2302
interface Vlan2302
  vrf member MyVRF_50002
  ip address 192.168.1.252/24 tag 12345
  no ip redirects
  no ipv6 redirects
  no shutdown
  hsrp version 2
  hsrp 1
    ip 192.168.1.253
    priority 120
    preempt
```

VLAN
definition

SVI Configs
with Active
FHRP

```
interface port-channel1
  switchport
  switchport mode trunk
  mtu 9216
  spanning-tree bpduguard disable
  spanning-tree guard root
  description vPC-aggregation-connected-to-vPC-access:Access1~Access2-vPC1
  no shutdown
  switchport trunk allowed vlan 2302
```

Allow VLAN
towards Access
devices

Network and VRF Configs

Pending Config - Classic-LAN - Access1

Pending Config Side-by-Side Comparison

```
interface port-channel1
 switchport
 switchport mode trunk
 description vPC-access-connected-to-vPC-aggregation:Agg2~Agg1-vPC1
 mtu 9216
 spanning-tree bpduguard disable
 spanning-tree guard loop
 no shutdown
 switchport trunk allowed vlan 2302
interface ethernet1/10
 switchport
 switchport mode trunk
 mtu 9216
 spanning-tree port type edge trunk
 no shutdown
 switchport trunk allowed vlan 2302
vlan 2302
```

Allow VLAN towards
Aggregation (uplink) and
Compute-Host (downlink)

VLAN definition

Pending Config - Classic-LAN - Access2

Pending Config Side-by-Side Comparison

```
interface port-channel1
 switchport
 switchport mode trunk
 mtu 9216
 spanning-tree bpduguard disable
 spanning-tree guard loop
 description vPC-access-connected-to-vPC-aggregation:Agg2~Agg1-vPC1
 no shutdown
 switchport trunk allowed vlan 2302
interface ethernet1/10
 switchport
 switchport mode trunk
 mtu 9216
 spanning-tree port type edge trunk
 no shutdown
 switchport trunk allowed vlan 2302
vlan 2302
```

Allow VLAN towards
Aggregation (uplink) and
Compute-Host
(downlink)

VLAN definition

Network and VRF Deployment Status in Enhanced Classic LAN

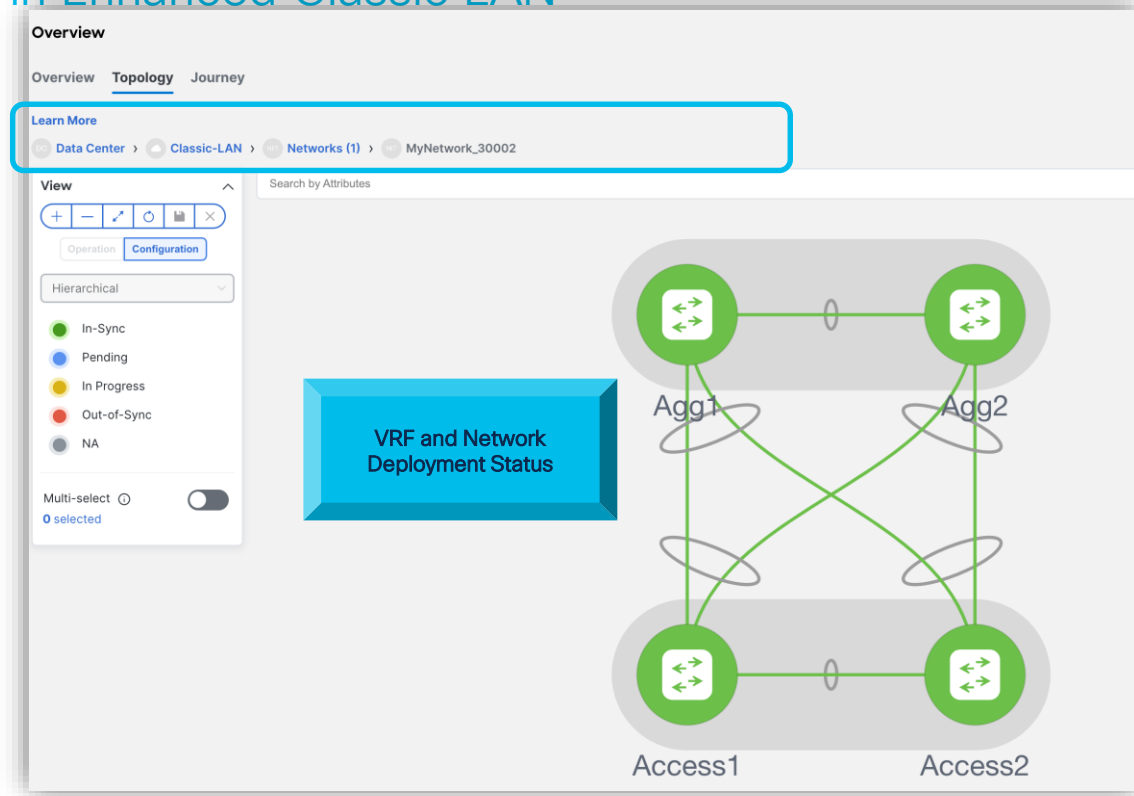

Manage and Deploy External Handoff for Enhanced Classic LAN with NDFC

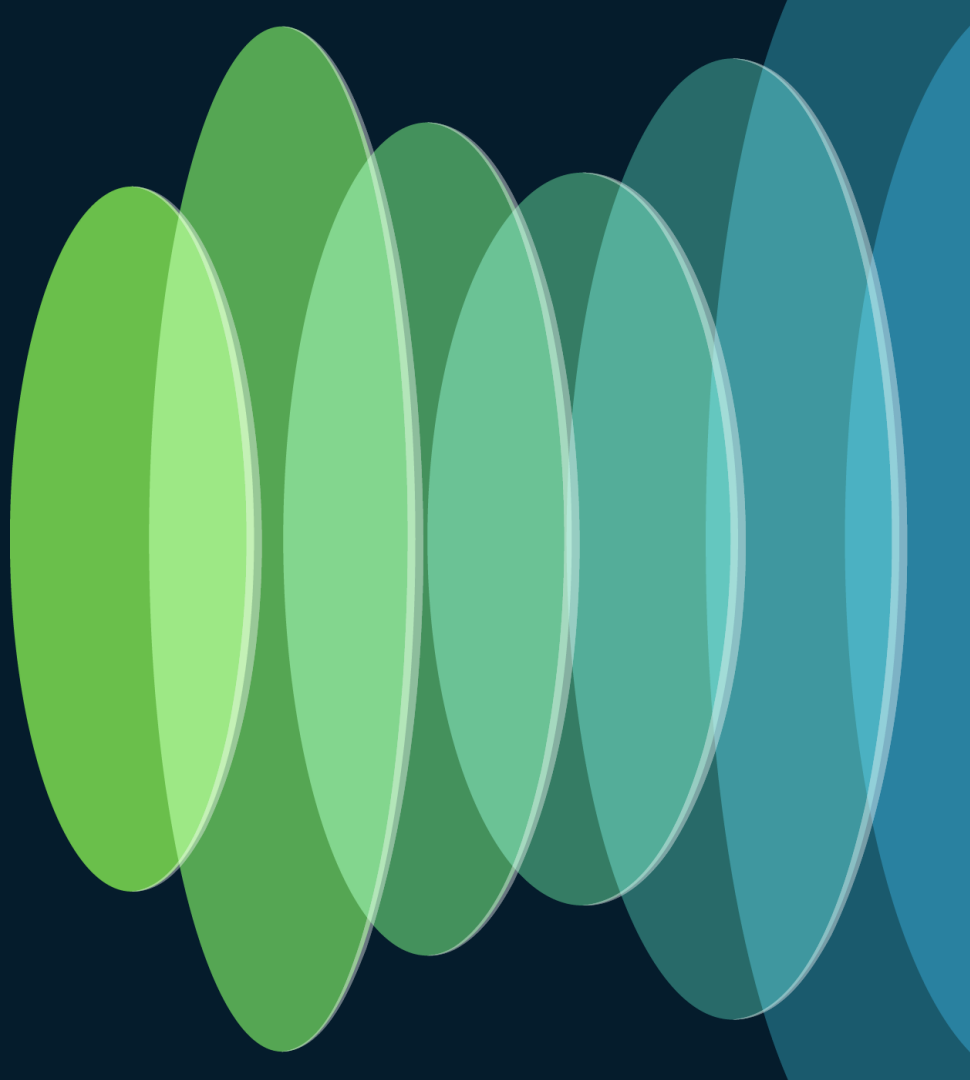

VRF-LITE IP Handoff

in Enhanced Classic LAN

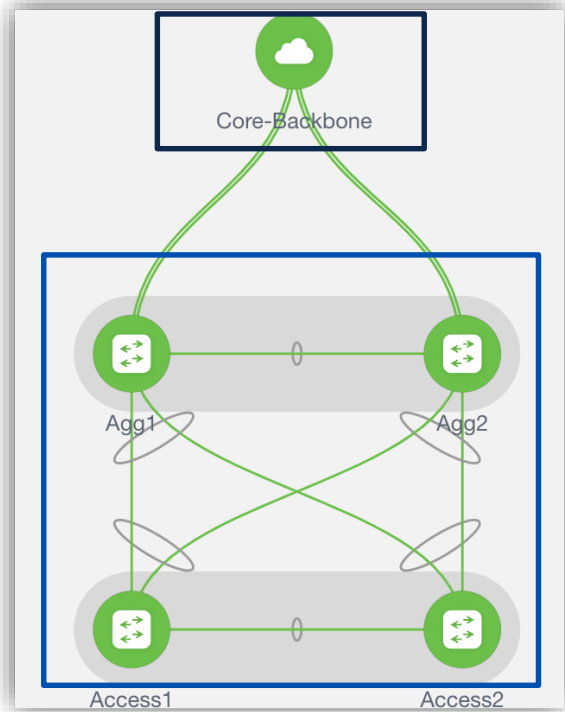

'External Connectivity Network' fabric with Core or Edge switches

'Enhanced Classic LAN' fabric with Access-Aggregation switches

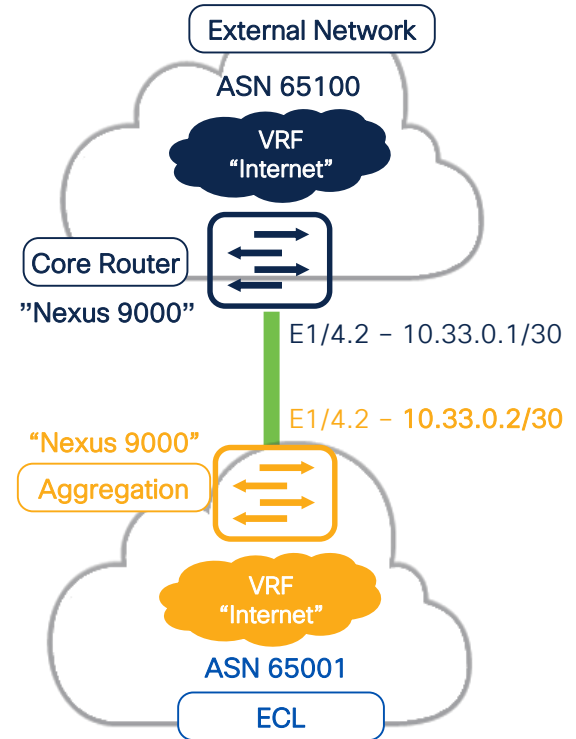

Who can be the External Router?

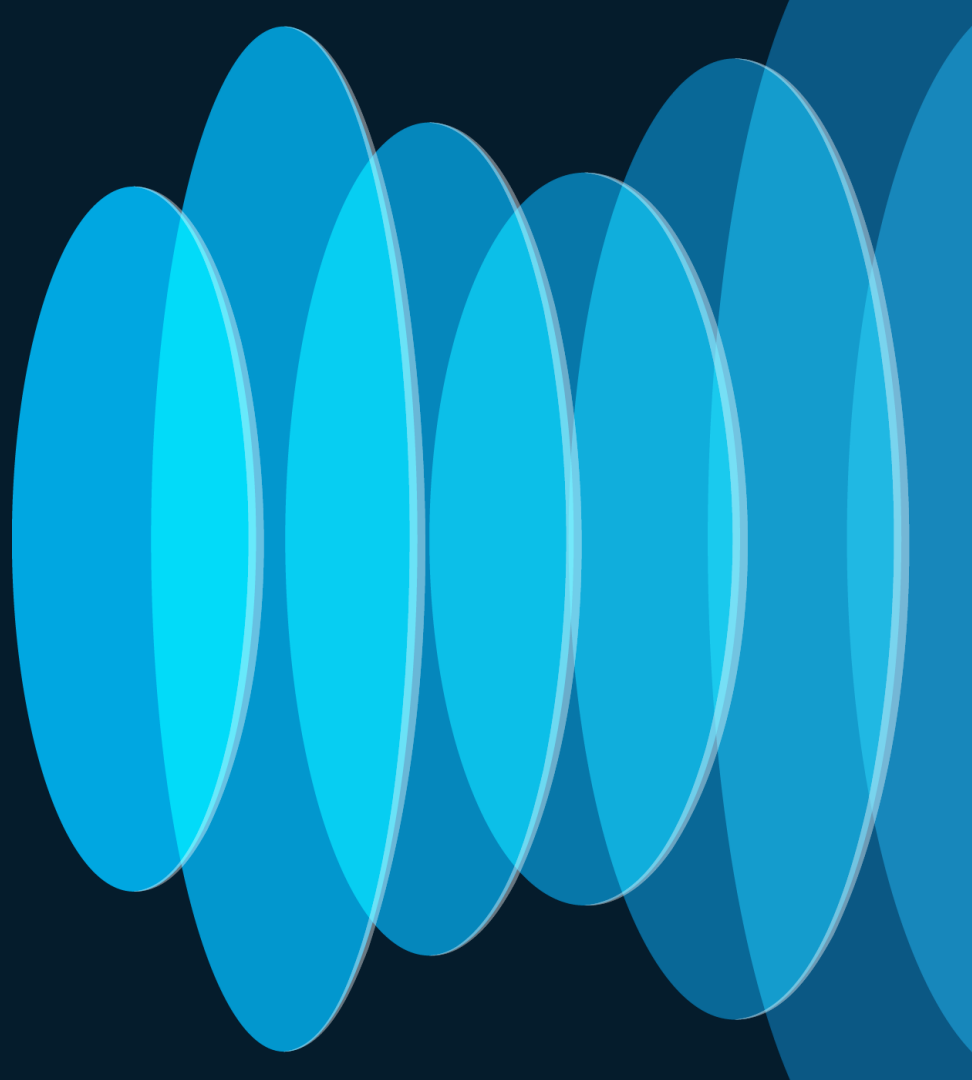

Core or Edge Router Placement Option

Nexus and Non-Nexus support

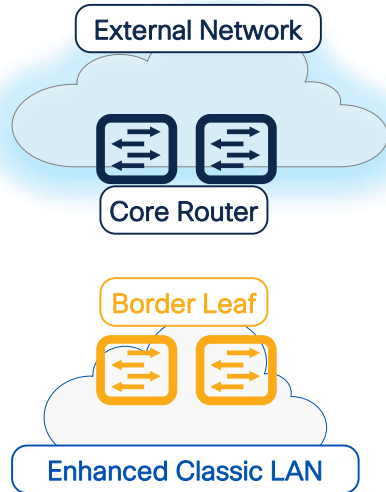

- Managed** NX-OS as Core Router
- ✓ - Nexus 9000
 - ✓ - Nexus 7000

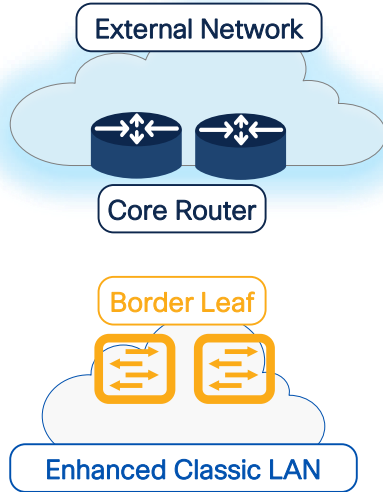

- Managed** IOS-XR as Core Router
- ✓ - Cisco 8000
 - ✓ - ASR 9000
 - ✓ - NCS 5500

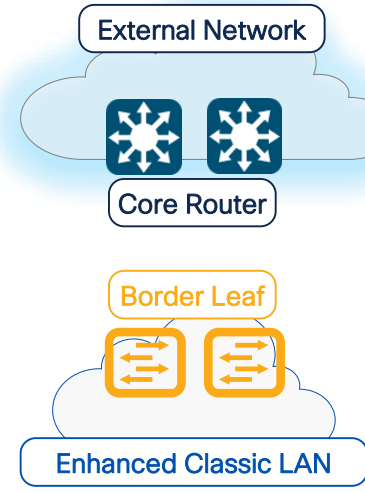

- Managed** IOS-XE as Core Router
- ✓ - Catalyst 9000
 - ✓ - Catalyst 8000
 - ✓ - ASR 1000
 - ✓ - CSR 1000

Managing Core/Edge Devices

- Part of 'External Connectivity Network' Fabric
- Create Fabric, discover Switches, set Role, Recalculate & Deploy

The screenshot displays the Cisco Fabric Manager interface for managing a fabric named 'Core-Backbone'. The interface is divided into several sections:

- General Parameters:** Shows the fabric name 'Core-Backbone', the BGP AS number '62222', and the 'Fabric Monitor Mode' checkbox.
- Add Switches - Fabric: Core-Backbone:** A dialog box for adding switches. It shows the 'Seed Switch Details' for a switch with IP 192.18.0.22-23, including authentication protocol (MDS) and username (admin). It also shows the 'Discovery Results' table with columns for Switch Name, Serial Number, IP Address, and Model.
- Select Role:** A dialog box for selecting a role for the switch. The 'Core Router' role is highlighted.
- Fabric Overview - Core-Backbone:** A table showing the discovered switches and their roles. The table has columns for Switch, IP Address, Role, Serial Number, Mode, Config Status, Oper Status, Discovery Status, and Model.

Switch Name	Serial Number	IP Address	Model
CoreSwitch-2	92NWQIKMBHH	192.18.0.23	N9K-C9300v
CoreSwitch-1	9FBR20MC7SJ	192.18.0.22	N9K-C9300v

Switch	IP Address	Role	Serial Number	Mode	Config Status	Oper Status	Discovery Status	Model
CoreSwitch-1	192.18.0.22	Leaf	9FBR20MC7SJ	Normal	NA	Minor	OK	N9K-C9300v
CoreSwitch-2	192.18.0.23	Leaf	92NWQIKMBHH	Normal	NA	Minor	OK	N9K-C9300v

Enabling Auto VRF-LITE

Aggregation to Nexus Edge/Core Router



Step 1

Create and Import

Define ECL and External Fabric. Set respective roles (e.g. Aggregation, Core)
Uncheck Fabric monitor mode in External Fabric if the Edge router is in managed mode



Step 2

IFC prototypes

Define IFC Type: "Auto"
Recalculate config and deploy



Step 3

Deploy Symmetric VRF-Lite Extension

Define Individual VRF extension on the Aggregation
NDFC will add Sub-int and eBGP peering on Aggregation and neighbor Core router
Deploy on ECL Fabric and External Network Fabric

The screenshot shows the configuration page for VRF Lite. The 'Aggregation-Core/Aggregation-Edge Connectivity' dropdown is set to 'Auto'. The 'VRF Lite Subinterface dot1q Range' is set to '2-511'. The 'Auto Generate VRF Lite Configuration on Aggregation and Core/Edge' checkbox is checked. The 'VRF Lite IP Version' dropdown is set to 'IPv4_only'. The 'IPv4 VRF Subnet IP Range' is set to '10.33.0.0/16'. The 'IPv4 VRF Lite Subnet Mask Length' is set to '30'. The interface also includes descriptive text for each field, such as 'VRF Lite Aggregation-Core and Aggregation-Edge Router Inter-Fabric Connection Options' and 'Flag that controls auto generation of VRF Lite sub-interface and peering configuration on Aggregation & Core/Edge devices. If set, auto created VRF Lite links will have 'Auto Generate Flag' enabled'.

VRF-LITE: Aggregation to Nexus Core

Defining IFC Link on physical interface

- IFC link has been defined
 - Policy should be `ext_fabric_setup`
 - IPs auto selected from VRF-Lite Subnet IP Range

Fabric Overview - Classic-LAN

Overview Switches **Links** Interfaces Interface Groups Policies Networks VRFs Event Analytics History Resources Metrics

Links Protocol View

Fabric Name contains Core

<input type="checkbox"/>	Fabric Name	Name	Policy	Info	Admin State	Oper State
<input type="checkbox"/>	Classic-LAN↔Core-Backbone	Agg1~Ethernet1/2---CoreSwitch-1~Ethernet1/2	ext_fabric_setup	Link Present	↑ Up	↑ Up
<input type="checkbox"/>	Core-Backbone←>Classic-LAN	CoreSwitch-2~Ethernet1/2---Agg2~Ethernet1/2	ext_fabric_setup	Link Present	↑ Up	↑ Up
<input type="checkbox"/>	Core-Backbone←>Classic-LAN	CoreSwitch-2~Ethernet1/3---Agg1~Ethernet1/3	ext_fabric_setup	Link Present	↑ Up	↑ Up
<input type="checkbox"/>	Core-Backbone←>Classic-LAN	CoreSwitch-1~Ethernet1/3---Agg2~Ethernet1/3	ext_fabric_setup	Link Present	↑ Up	↑ Up

VRF-LITE: Aggregation to Nexus Core

Defining VRF extensions on Aggregation

- Verify ECL fabric VRFs were created and customize if needed
 - LAN > Fabrics > **Double click** (your ECL Fabric) > VRFs

Fabric Overview - Classic-LAN

Overview Switches Links Interfaces Interface Groups Policies Network **VRFs** Event Analytics History Resources Metrics

VRF Name == Internet X Edit Clear All Actions ^

<input checked="" type="checkbox"/> VRF Name	VRF Status
<input checked="" type="checkbox"/> Internet	● NA

Create
Edit
Multi-Attach
Multi-Detach
Deploy
Import
Export

Edit VRF if you want to modify route advertisement or other VRF specifics

VRF-LITE: Aggregation to Nexus Core

Defining VRF extensions on Aggregation

Edit VRF

VRF Name*
Internet

VRF Template*
VRF_Classic >

General Parameters **Advanced**

Routing Protocol
ebgp

IP Version*
IPv4_only

VRF Lite Aggregation-Core or Collapsed Core-WAN Peer Settings

Choice of IPv4, IPv6 or both

General Parameters **Advanced**

Redistribute Direct Route Map
FABRIC-RMAP-REDIST-SUBNET

Max BGP Paths
2

Static Route Information

Config Static 0/0 Route

Enable BGP Authentication

Flag to control Static Default Route configuration

Enable Auto Peering over SVI Between VPC Aggs



Flag to Control per VRF iBGP/OSPF Peering between Aggs. The protocol to use is based on vrf-lite routing protocol in Fabric setting

VRF-LITE: Aggregation to Nexus Core

Defining VRF extensions on Aggregation

- **Attach** VRF to Aggregation and extend through VRF-Lite

VRF Overview - Internet

Overview **VRF Attachments** Networks

Note: Access switches are not directly displayed, but are configured via aggregation switches.

Filter by attributes

<input checked="" type="checkbox"/>	VRF Name	VLAN ID	Switch	Status	Attachment	Switch Role	Actions
<input checked="" type="checkbox"/>	Internet		Agg1	NA	Detached	aggregation	History Edit Preview Deploy Import Export Quick Attach Quick Detach
<input checked="" type="checkbox"/>	Internet		Agg2	NA	Detached	aggregation	

VRF-LITE: Aggregation to Nexus Core

Defining VRF extensions on Aggregation

Agg1(9EEM1T58D89) - Agg2(9UEXH9V6Z9L)

Detach Attach

Extend*
VRF_LITE

Agg1(9EEM1T58D89)

CLI Freeform Config

Edit >

All configs should strictly match the 'show run' output, including cases and new line
Any mismatches will yield unexpected diffs during deploy

VLAN
2001

Agg2(9UEXH9V6Z9L)

CLI Freeform Config

Edit >

All configs should strictly match the 'show run' output, including cases and new line
Any mismatches will yield unexpected diffs during deploy

VLAN
2001

VLAN Name

SVI IPv4 Address/Netmask
10.33.0.17/30

vPC Peer SVI IPv4 Address
10.33.0.18

SVI IPv6 Address/Netmask

vPC Peer SVI IPv6 Address

SVI Description

Extension

Filter by attributes

Action	Attached	Source Switch	Type	IF NAME	Dest. Switch	Dest. Interface	Encapsul... Dot1q VLAN ID	IPv4 Prefix/Ma...	IP Tag	Neighbor IPv4 Address	Neighbor ASN
Edit	Attached	Agg1	VRF_LITE	Ethernet1/3	CoreSwitch-2	Ethernet1/3	2	10.33.0.2/30		10.33.0.1	65534
Edit	Attached	Agg1	VRF_LITE	Ethernet1/2	CoreSwitch-1	Ethernet1/2	2	10.33.0.5/30		10.33.0.6	65534
Edit	Attached	Agg2	VRF_LITE	Ethernet1/2	CoreSwitch-2	Ethernet1/2	2	10.33.0.10/30		10.33.0.9	65534
Edit	Attached	Agg2	VRF_LITE	Ethernet1/3	CoreSwitch-1	Ethernet1/3	2	10.33.0.14/30		10.33.0.13	65534

Attach VRF

VRF-LITE: Aggregation to Nexus Core

Preview and Deploy VRF extensions on Aggregation

Pending Config

```
vlan 2001
vrf context Internet
ip route 0.0.0.0/0 10.33.0.1
ip route 0.0.0.0/0 10.33.0.6
address-family ipv4 unicast
```

VRF Configs

Default route static
towards External Cores

```
exit
interface Vlan2001
vrf member Internet
ip address 10.33.0.17/30
mtu 9216
no ip redirects
no ipv6 redirects
no shutdown
```

Route-Map to advertise all connected
SVIs to External Cores

```
exit
router bgp 65535
vrf Internet
address-family ipv4 unicast
redistribute direct route-map FABRIC-RMAP-REDIST-SUBNET
```

eBGP IPv4 VRF neighbor
configs

```
exit
neighbor 10.33.0.1
remote-as 65534
address-family ipv4 unicast
send-community both
exit
neighbor 10.33.0.6
remote-as 65534
address-family ipv4 unicast
send-community both
```

```
interface ethernet1/3.2
encapsulation dot1q 2
mtu 9216
vrf member Internet
ip address 10.33.0.2/30
no shutdown
```

Aggregation Sub-
Interface Config

```
interface ethernet1/2.2
encapsulation dot1q 2
mtu 9216
vrf member Internet
ip address 10.33.0.5/30
no shutdown
```

VRF-LITE: Aggregation to Nexus Core

Preview and Deploy VRF extensions on External Core

Pending Config - Core-Backbone - CoreSwitch-2

Pending Config Side-by-Side Comparison

```
vrf context internet
  address-family ipv4 unicast
exit
router bgp 65534
  vrf internet
```

```
  address-family ipv4 unicast
    neighbor 10.33.0.10
    remote-as 65535
  address-family ipv4 unicast
```

```
    send-community both
  exit
```

```
  neighbor 10.33.0.2
    remote-as 65535
  address-family ipv4 unicast
    send-community both
```

VRF Configs

eBGP IPv4 VRF neighbor configs

```
interface ethernet1/2
  mtu 9216
  description connected-to-Agg2-Ethernet1/2
  no switchport
  no shutdown
interface ethernet1/3
  description connected-to-Agg1-Ethernet1/3
  mtu 9216
  no switchport
  no shutdown
interface ethernet1/2.2
  mtu 9216
  vrf member internet
  encapsulation dot1q 2
  ip address 10.33.0.9/30
  no shutdown
interface ethernet1/3.2
  mtu 9216
  vrf member internet
  encapsulation dot1q 2
  ip address 10.33.0.1/30
  no shutdown
```

Core Physical and Sub-Interface Config

Existing
Network? Let's
do a Brownfield
import

Enhanced Classic LAN **Brownfield**

Already using 3-Tier LAN?
Want to use NDFC for managing your fabric?



NDFC fully supports
Brownfield



Non-disruptive import
of existing 3-Tier
Classic LAN
deployments



Learns topology, all
configuration,
associated resources, IP
subnets, VLANs, STP,
etc.



Start Managing fabric
as if provisioned from
NDFC

Step 2 Discover

Import switches with **Preserve Config**
Define switch Roles (Access and Aggregation)



Step 1 Create

Define fabric settings (FHRP, Routing, VLAN) -
Match STP, VPC pairing, VLAN pool, etc.



Step 3 Recalculate and Deploy

Sanity checks for mis-config and Normalizes configuration
to best practices

Enhanced Classic LAN Brownfield

Existing Networks and VRFs are learnt on a Brownfield import

The image displays two screenshots from the Cisco Fabric Manager interface. The top screenshot shows the 'Fabric Overview - Bf-Fab' page with the 'Networks' tab selected. A table lists various networks with their VRF names, IP addresses, and deployment status. The bottom screenshot shows the 'VRFs' tab, listing VRF names and their deployment status.

Networks Table:

Network Name	VRF Name	IPv4 Gateway/Suffix	IPv6 Gateway/Prefix	Network Status	VLAN ID	Interface Group
Auto_Net_VLAN301	default	192.168.31.1/24		DEPLOYED	301	
Auto_Net_VLAN300	NA			DEPLOYED	300	
Auto_Net_VLAN2303	NA			DEPLOYED	2303	
Auto_Net_VLAN2302	myvrf_50002	192.168.1.1/24				
Auto_Net_VLAN2304	NA					
Auto_Net_VLAN32	vrf-prod	192.168.32.1/24				
Auto_Net_VLAN34	vrf-prod		2001::192:168:34:1/120			
Auto_Net_VLAN2301	NA					
Auto_Net_VLAN2300	nonprod	1.1.1.1/24	2001::1:1:1:1/112			

VRFs Table:

VRF Name	VRF Status
default	DEPLOYED
vrf-prod	DEPLOYED
myvrf_50002	DEPLOYED
nonprod	DEPLOYED

Enhanced Classic LAN

Day-2

Day 2 features for Enhanced Classic LAN Fabrics

- Image Management- Upgrades, Downgrades, EPLDs, RPMs, SMUs
- Change Control and Rollback, RMA, RBAC
- Inventory View, Topology View
- Event Analytics
- Deployment History, Audit Logs
- Backup & Restore
- Performance Metrics, Link and Interface stats, Protocol Views
- Programmable Reports
- Virtual infrastructure (VMM, K8s, OpenStack) Visibility
- Integration with Nexus Dashboard Insights (NDI) *

Verification through NDFC

Keeping you away from CLI



Step 1

Verify Network and VRF
attachments

Status:

Network Status **Deployed**

VRF Status **Deployed**



Step 2

Deployment History

Configuration Execution Status:

Verify Deployment History Status **Success** for
Fabric, Interfaces, and more



Step 3

Show commands

Service / features status
(CLI through NDFC)

Attachment deployment status

Job execution perspective

Config Preview Deploy Progress

Filter by attributes

Switch Name	IP Address	Status	Status Description	Progress
Access3	192.18.0.15	STARTED	Deployment in progress.	Executed 120 / 452
Agg3	192.18.0.18	STARTED	Deployment in progress.	Executed 90 / 452
Access4	192.18.0.20	STARTED	Deployment in progress.	Executed 110 / 452
Access5	192.18.0.21	STARTED	Deployment in progress.	Executed 110 / 452
Agg4	192.18.0.19	STARTED	Deployment in progress.	Executed 82 / 452

Multi-Stage Preview and Deployment

Config Preview Deploy Progress

Filter by attributes

Switch Name	IP Address	Status	Status Description	Progress
Access4	192.18.0.20	FAILED	Deployment failed. Check deployment history for more information. View Details	Executed 0 / 3

Success or Failure deployment details

Filter by attributes

Switch Name	IP Address	Status	Status Description	Progress
Access3	192.18.0.15	SUCCESS	Deployment completed.	Executed 452 / 452
Agg3	192.18.0.18	SUCCESS	Deployment completed.	Executed 452 / 452
Access4	192.18.0.20	SUCCESS	Deployment completed.	Executed 452 / 452
Access5	192.18.0.21	SUCCESS	Deployment completed.	Executed 452 / 452
Agg4	192.18.0.19	SUCCESS	Deployment completed.	Executed 452 / 452

Deployment History Tool

Commands execution perspective

Overview Switches Links Interfaces Interface Groups Policies Networks VRFs Event Analytics **History** Resources

Deployment History Policy Change History

Filter by attributes

HostName	Entity Name	Entity Type	Source	Commands	Status	Serial Number	Status Description	Admin	Time
Access3	Ethernet1/7	INTERFACE	UNDERLAY	no shutdown	SUCCESS	95HAQMOPOM8	Successfully deployed	admin	May 16 21
Access3	Ethernet1/8	INTERFACE	UNDERLAY	switchport trunk allowed vlan none	SUCCESS	95HAQMOPOM8	Successfully deployed	admin	May 16 21
Access3	SWITCH	SWITCH	UNDERLAY	configure terminal	SUCCESS	95HAQMOPOM8	Successfully deployed	admin	May 16 21
Access3	Ethernet1/9	INTERFACE	UNDERLAY	spanning-tree port type edge trunk	SUCCESS	95HAQMOPOM8	Successfully deployed	admin	May 16 21
Access3	SWITCH	SWITCH	UNDERLAY	switchport mode trunk	FAILED	95HAQMOPOM8	CLI command 'no vlan 1' failed with following error:Delivery failed with message:Deletion of VLAN 1 is not allowed!!	admin	May 16 21
Access3	SWITCH	SWITCH	UNDERLAY	mtu 9216	NOT_EXEC	95HAQMOPOM8	Delivery failed with message:Check error in results	admin	May 16 21
Access5	SWITCH	SWITCH	UNDERLAY	switchport mode trunk	FAILED	9FVACY3Q376	CLI command 'no vlan 1' failed with following error:Delivery failed with message:Deletion of VLAN 1 is not allowed!!	admin	May 16 21
Access5	SWITCH	SWITCH	UNDERLAY	spanning-tree port type edge trunk	NOT_EXEC	9FVACY3Q376	Delivery failed with message:Check error in results	admin	May 16 21
Access4	SWITCH	SWITCH	UNDERLAY	switchport mode trunk	FAILED	9NTCZGN5DDE	CLI command 'no vlan 1' failed with following error:Delivery failed with message:Deletion of VLAN 1 is not allowed!!	admin	May 16 21

Config Status CLI Response

```

interface ethernet1/9
switchport
switchport mode trunk
mtu 9216

spanning-tree port type edge trunk
no shutdown
switchport trunk allowed vlan none
configure terminal
    
```

Edge port type (portfast) should only be enabled on ports connected to a single host. Connecting hubs, concentrators, switches, bridges, etc... to this interface when edge port type (portfast) is enabled, can cause temporary bridging loops. Use with CAUTION

CLI response messages for easier troubleshooting

Config	Status	CLI Response
no vlan 1	FAILED	Delivery failed with message:Deletion of VLAN 1 is not allowed!!

Show Commands Tool

Switch Config perspective

The screenshot shows the 'Switch Overview - Agg3' dashboard. The 'Overview' tab is active, displaying switch information, performance metrics, and interface status. A 'Show Commands' menu is open, highlighting the 'Show Commands' option. The dashboard includes sections for Switch Info, Performance, Interfaces, and Alarms.

Switch Info

Switch Name	IP Address	Serial Number	Role	Switch Health	Group
Agg3	192.18.0.18	9HLDY7Z3980	access	MINOR	Classic-LAN-fabric2

Performance

CPU Utilization: 25% (Minor)

Memory: 48%

Interfaces

Admin Status: 65 (up)

Operational Status: 65 (up)

Sync Status: 65 (In-Sync)

Logical Interfaces: 0 (vPC)

Alarms

59 (critical, major)

Module

Restore Switch

Show Commands

Exec Commands

NDFC pre-built commands or user commands

The screenshot shows the 'Switch show commands - Agg3' window. The 'Commands*' dropdown is set to 'show_mac_and_arp'. The 'Variables' section has 'VRF*' set to 'all'. The output shows the command execution results for the 'show mac address-table' command.

Commands*

show_mac_and_arp

Variables

VRF*

all

```
1
2 #show mac address-table
3 Legend:
4 * - primary entry, G - Gateway MAC, (R) - Routed MAC, O - Overlay MAC
5 age - seconds since last seen, + - primary entry using vPC Peer-Link,
6 (T) - True, (F) - False, C - ControlPlane MAC, - - vswan
7 VLAN MAC Address Type age Secure NTFY Ports
8 -----
9 G - 5219.1a5c.1b08 static - F F sup-eth1(R)
10
11 #show ip arp vrf all
12 Flags: * - Adjacencies learnt on non-active FHRP router
13 + - Adjacencies synced via CFSOE
14 # - Adjacencies Throttled for Clean
15 CP - Added via L2RIB, Control plane Adjacencies
16 PS - Added via L2RIB, Peer Sync
17 RO - Re-Originated Peer Sync Entry
18 D - Static Adjacencies attached to down interface
19
20 IP ARP Table for all contexts
21 Total number of entries: 2
22 Address Age MAC Address Interface Flags
23 192.18.0.8 00:00:15 0050.5681.e31e mgmt0
24 192.18.0.10 00:15:27 0050.5681.e31e mgmt0
25
```

Co-existence/ Migration from Classic LAN to VXLAN

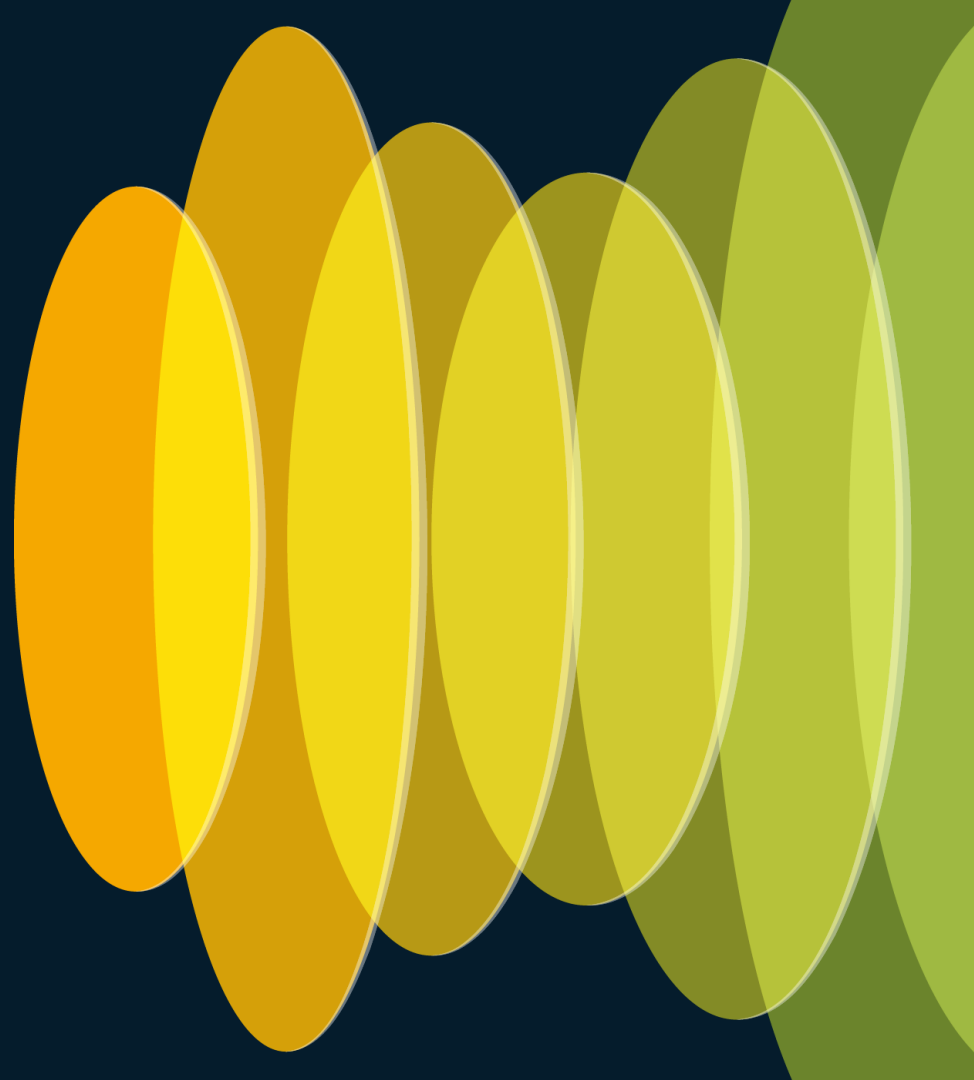

Data Center Network Challenges

Hierarchical Topology

Scale-Up with Big
Centralized Chassis
(Agg*)

STP limits full bandwidth
utilization

Hairpinning

Suboptimal performance,
traffic forwarding
constrained by spanning-
tree rules

Rigid Network Service
Placement (L4-L7)

Limited Endpoint Mobility

Flood&Learn

Convergence
dependent on Single
Tree and MAC Flush
(TCN)

Exposed to Large
Broadcast Domains
(All Access and
Agg*)

Data Center Network Challenges

Solving the Legacy Methods Challenges

Hierarchical Topology

Scale-Out

- Adding Spine for Bandwidth and Redundancy
- Adding Leaf for Port Capacity

All Links are used (IP ECMP)

No More Hairpinning

Default Gateway at Every Leaf (Distributed Anycast Gateway)

Flexible Network Service Placement (L4-L7)

Pervasive Subnet and Endpoint Mobility

Control-Plane Learned

Active Learning and Distribution with BGP EVPN

Reduces the Broadcast Domain by configuring VLANs where Needed

Next Generation– VXLAN BGP EVPN Fabrics

Becoming Industry De-Facto Standard

An IGP is recommended for the underlay (OSPF or IS-IS)

- BGP can also be used if needed

BGP EVPN must be used in the overlay to exchange endpoints information

- Spines act as route-reflectors

VXLAN is used to transport endpoint traffic in the fabric

- Leafs are considered VTEP as they encapsulate and decapsulate VXLAN traffic

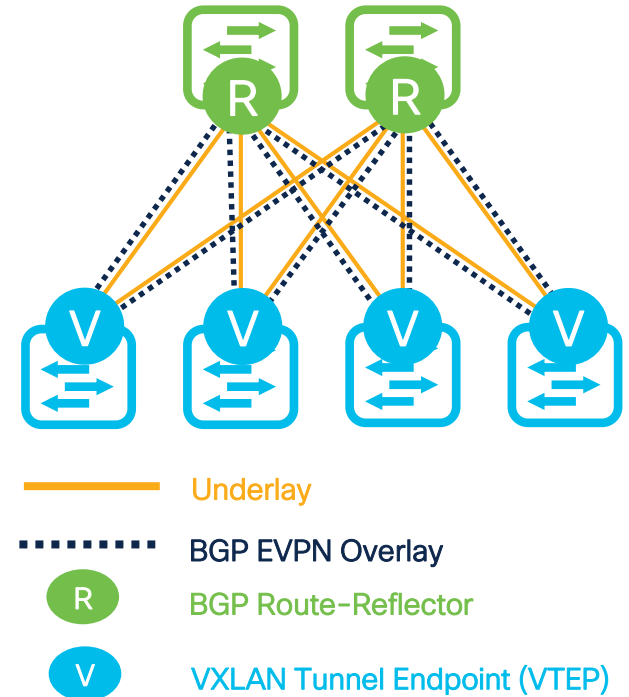

VXLAN Deployment in a few clicks with NDFC

Un-provisioned switches

Cisco best practice implemented

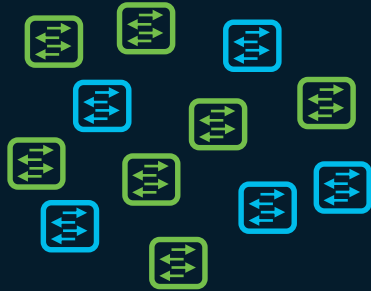

Within NDFC
select fabric builder



Fast, automated process

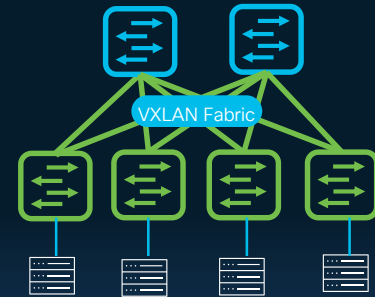

Benefit

Accelerate fabric deployments

Automated consistency

Minimize risk

Support for both Greenfield and Brownfield deployment

Classic LAN to VXLAN Fabric connectivity

- Layer 2 and Layer 3 connectivity between old and new is needed
- Allows communication between endpoints at various migration stages
- Allows communication of migrated endpoints to old external core
- In CE network this should be done at the aggregation layer where the L2/L3 demarcation exists
- In the VXLAN network this could be any switch that provides a VTEP

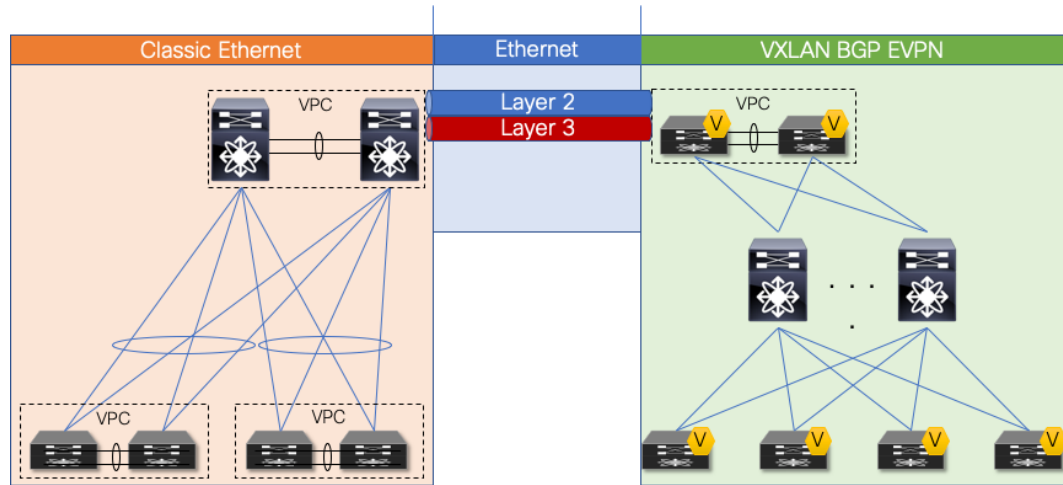

Migration of Gateways

- Enhanced Classic LAN uses Centralized Gateway concept with FHRP.
- VXLAN uses Distributed Anycast Gateway (DAG) concept.
- For co-existence of these two disparate kind of gateways, i.e keep both running at the same time, NX-OS introduced a new feature starting 10.2(3) called Proxy-ARP
- As long as the switches are running NX-OS 10.2(3) or after, both DAG and FHRP gateways can co-exist and NDFC can be used to provision the same
- For NX-OS 10.2(3) and prior, only one kind of Gateway can exist. Users need to bring down the Gateway for workloads from Brownfield Enhanced Classic LAN network and move it to the Greenfield VXLAN Fabric with Anycast Gateway

Migration to VXLAN BGP EVPN Fabric

Using NDFC- High Level Steps

Step 1

Discover existing Brownfield Classic Ethernet Network using ECL. Supported roles are access and aggregation. NDFC will learn existing Networks and VRFs

Step 2

Setup Greenfield Data Center VXLAN BGP EVPN fabric. Discover and import greenfield switches in NDFC for VXLAN Day-0 and Day-1 configs

Step 3

Create Layer-2 VPC port-channel and Layer-3 IP handoff between Aggregation switches in ECL and Border Leafs in VXLAN fabric

Step 4

Deploy new Networks from VXLAN fabric. Migrate existing Networks from ECL to VXLAN. Co-existence of FHRP and DAG is supported started NX-OS 10.2(3)

Step 5

Classic Ethernet Network in ECL can eventually be retired as the refresh to Nexus 9000 in VXLAN BGP EVPN fabric completes

For more information

Attend BRKDCN-2951 (Wed, 5th June, 2:30 PM)

Conclusion

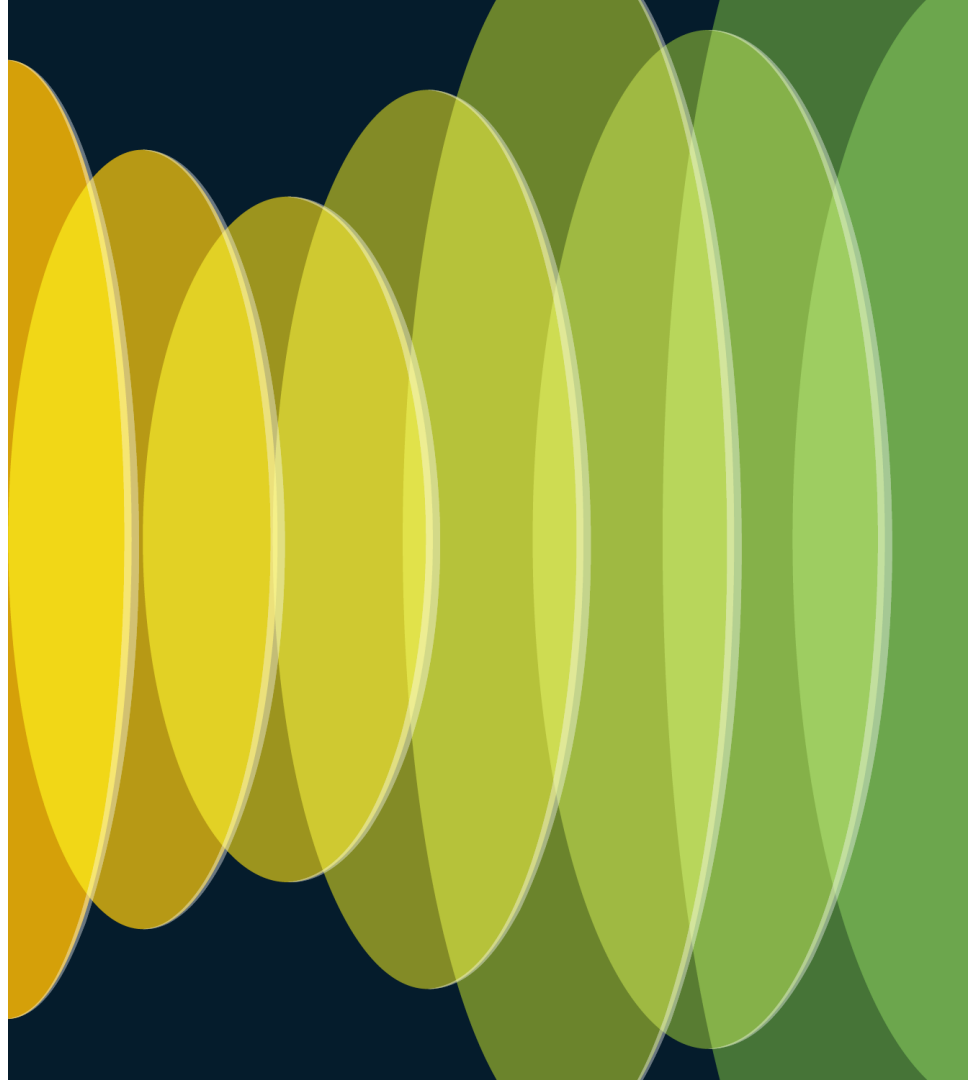

Conclusion

Key points to remember



- 1** Investment protection for Nexus 7000 and Nexus 9000 for Classic Ethernet Networks. Support for Brownfield and Greenfield.
- 2** Simplified Day-0 and Day-1 configuration provision using Cisco's best practices including FHRP, STP, vPC, IP routing, and more!
- 3** Extended Day-2 support using intuitive Image management, Performance monitoring, and VMM visualization

Easily license your NDFC

Software included with switch subscription licenses



Tier-based



NXOS Essentials, Advantage, Premier

Or



DCN Essentials, Advantage, Premier

Install base (NX-OS)

New purchase (NX-OS)

References

- Deep dive demo - [Management of Data Center Architectures using NDFC - YouTube](#)
- Installation of Nexus Dashboard - <https://www.cisco.com/c/en/us/support/data-center-analytics/nexus-dashboard/products-installation-guides-list.html>
- Nexus Dashboard capacity planning tool - <https://www.cisco.com/c/dam/en/us/td/docs/dcn/tools/nd-sizing/index.html>
- NDFC user guide - <https://www.cisco.com/c/en/us/support/cloud-systems-management/prime-data-center-network-manager/products-installation-and-configuration-guides-list.html>
- Whitepaper on ECL - <https://www.cisco.com/c/en/us/td/docs/dcn/whitepapers/enhanced-classic-lan-in-cisco-ndfc-1213.html>
- Migration from Classic LAN to VXLAN - <https://www.cisco.com/c/en/us/td/docs/dcn/whitepapers/migrating-classic-ethernet-to-vxlan-bgp-evpn-white-paper.html#CiscoNexusDashboardFabricController>

Complete Your Session Evaluations



Complete a minimum of 4 session surveys and the Overall Event Survey to be entered in a drawing to **win 1 of 5 full conference passes** to Cisco Live 2025.



Earn 100 points per survey completed and compete on the Cisco Live Challenge leaderboard.



Level up and earn **exclusive prizes!**



Complete your surveys in the **Cisco Live mobile app.**

Continue your education

- Visit the Cisco Showcase for related demos
- Book your one-on-one Meet the Engineer meeting
- Attend the interactive education with DevNet, Capture the Flag, and Walk-in Labs
- Visit the On-Demand Library for more sessions at www.CiscoLive.com/on-demand



The bridge to possible

Thank you

CISCO *Live!*

#CiscoLive